

# Moraic versus Constituent Syllables\*

Roland Noske

## 1. Introduction

In the discussion on the structure of the syllable, several models have been put forth. Recently, there has been a trend, particularly among linguists in the United States, (e.g., Hyman (1984,1985), McCarthy & Prince (1986), Itô (1986,1988), Hayes (1989), Archangeli (1989,1991)), towards models in which the concept of mora, defined as the element which expresses phonological weight, plays a major role in syllable structure. More specifically, syllabic subconstituents and elements expressing syllabic weight have been identified with each other.

Hyman (1984,1985) was the first to contribute to the current wave of interest in the mora as a syllabic building block. In his theory, moras replace syllables altogether. He takes the radical view that it is not the *syllable* which is basic, but *syllabicity*. The basic concept expressing syllabicity is the Weight Unit (WU). Each segment has a WU. Onset consonants become weightless by the working of the universal Onset Creation Rule (OCR), given in (1) (1985:15):

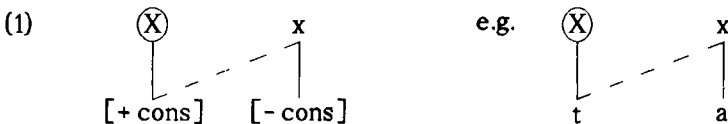

The circle around the *X* indicates that this element is delinked and subsequently deleted. The OCR reduces the underlying two WU's of the sequence *ta* to one. Hence it expresses the fact that onsets are generally not weight-bearing. At the same time, the OCR accounts for the general obser-

---

\* We thank Karl Heinz Ramers, Henk van Riemsdijk, Norval Smith, Richard Wiese and Martha Young-Scholten for comments on earlier versions of this paper.

vation that in a CVC sequence, the C belongs to the second syllable.

Hyman does not wish to distinguish between C's and V's. In his theory, the most sonorous element dominated by a WU is the 'bearer' of syllabicity. This assumption was strongly criticised in a review by Odden (1986).

Odden shows that under Hyman's assumptions it is not possible to distinguish between elements which only differ in syllabicity, e.g., English 'ear' [ir] vs. (reduced) 'your' [jɹ] (1986:670). Odden also points out (1986:670-671) that Hyman's theory cannot account either for the contrast between syllabic and nonsyllabic C's in comparable environments. This contrast occurs in certain languages, e.g. Kimatuumbi.

Hayes (1989) tries to remedy Odden's objections to Hyman's theory. In this article the author devises a different moraic syllable model and tries to show that this particular version of moraic theory is capable of explaining phenomena of compensatory lengthening (henceforth: CL). According to Hayes, his theory predicts the existing types of CL and excludes the non-existing types.

Hayes' theory which has been quite influential during the past two years, has been widely accepted as a theory of the internal structure of the syllable. We wish to challenge this theory and the concept of an internal syllable structure based on the mora in general, and to show that a true constituent model of the syllable, based on autosegmental principles of structure building, is more adequate.

Below, we will give a summary of Hayes' theory. Then, we will show that this theory entails a breach of fundamental and necessary assumptions in nonlinear phonology. We will also show that some important facts on which the theory is based were incorrect.

The second half of this paper consists of the outline of a theory of syllabification based on principles of association and representation which are truly autosegmental in nature. We show that this theory can account for all genuine CL cases and excludes the non-existing types of CL, while it does not encounter the theoretical difficulties characterising mora theory.

## 2. The moraic theory of Hayes (1989)

### 2.1 Syllable structure and syllabification

Hayes argues that various types of compensatory lengthening phenomena provide evidence for a model in which segments are dominated by moras, rather than by skeletal elements (X's, or C's and V's). By using moras, syllable weight is expressed directly in the syllable structure. Vowels normally bear a mora underlyingly, while consonants do not. It is in this point that Hayes' theory differs significantly from Hyman's: elements which are not usually syllabic do not underlyingly bear a mora in Hayes' theory (except for geminate consonants, see below).

In a language in which both CVV and CVC syllables count as heavy, the following structures are assumed for the three types of syllables ( $\mu$  = mora):

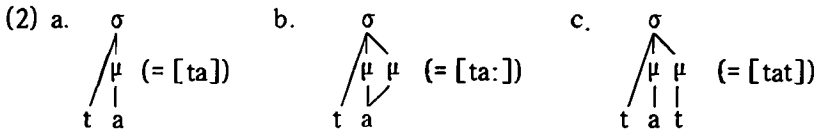

In a language where a CVC syllable does not count as heavy the structure of this syllable is:

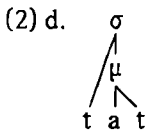

In this theory, there are two sources for moras. Moras can be underlying or can be assigned by rule. Let us first take underlying moras. The three way contrast between nonsyllabic vowels (glides), short vowels and long vowels is expressed by the contrast in domination by zero, one and two moras respectively. The forms in (3a,b,c) represent a glide, a short vowel and a long vowel respectively (Hayes 1989:256).

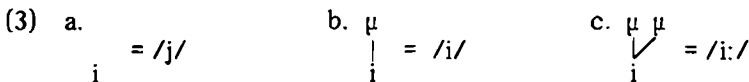

As for consonants, geminates are underlyingly represented as being dominated by one mora, while single consonants are not dominated by a mora:

- (4) a.  $\begin{array}{c} \mu \\ | \\ n \end{array} = /n/$       b.  $\begin{array}{c} \mu \\ | \\ n \end{array} = /nn/$

Syllabification in Hayes' mora theory takes place by "(a) selection of certain sonorous moraic segments, on a language-specific basis, for domination by a syllable node; (b) adjunction of onset consonants to the syllable node, and of coda consonants to the preceding mora" (1989:257):

- (5) a.  $\begin{array}{c} \mu \\ | \\ t \end{array} \begin{array}{c} a \\ | \\ \end{array} \Rightarrow \begin{array}{c} \sigma \\ | \\ \mu \\ | \\ t \end{array} \begin{array}{c} a \\ | \\ \end{array} \Rightarrow \begin{array}{c} \sigma \\ / \quad | \\ \mu \quad | \\ t \quad a \end{array}$       b.  $\begin{array}{c} \mu \quad \mu \\ / \quad \backslash \\ t \quad a \end{array} \Rightarrow \begin{array}{c} \sigma \\ / \quad | \quad \backslash \\ \mu \quad \mu \end{array} \Rightarrow \begin{array}{c} \sigma \\ / \quad | \quad \backslash \\ \mu \quad \mu \end{array}$
- c.  $\begin{array}{c} \mu \\ | \\ a \end{array} \begin{array}{c} t \\ | \\ \end{array} \Rightarrow \begin{array}{c} \sigma \\ | \\ \mu \\ | \\ a \end{array} \begin{array}{c} t \\ | \\ \end{array} \Rightarrow \begin{array}{c} \sigma \\ | \\ \mu \\ | \quad \backslash \\ a \quad t \end{array}$       d.  $\begin{array}{c} \mu \\ | \\ a \end{array} \begin{array}{c} n \quad t \\ | \quad | \\ \end{array} \Rightarrow \begin{array}{c} \sigma \\ | \\ \mu \\ | \\ a \end{array} \begin{array}{c} n \quad t \\ | \quad | \\ \end{array} \Rightarrow \begin{array}{c} \sigma \\ | \\ \mu \\ | \quad \backslash \\ a \quad n \quad t \end{array}$

Hayes treats syllabification only in a cursory manner. He does not explain why coda consonants are linked to a mora while onset consonants are linked directly to the syllable node. Note that the second part of his syllabification proposal (the adjunction of the onset and coda consonants) in fact consists of the working of the autosegmental convention of *dumping*. In (5c) the derivation produces a light CVC syllable, because there is only one mora. Languages in which a CVC syllable counts as heavy, are assumed to have an additional language specific rule, which *assigns* a mora to a consonant in a specific position: the *Weight by Position* rule (1989:258):

(6) *Weight by Position*

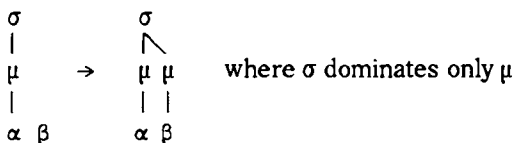

If this rule is present in the rule inventory of the language in question, the

derivation of a CVC syllable proceeds as follows:

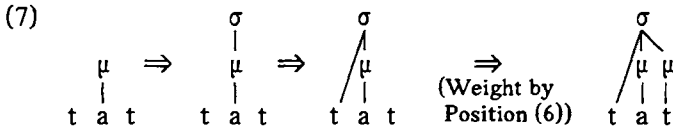

Heterosyllabic geminates are syllabified as follows:

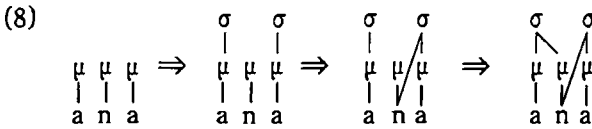

The consonant melody linked to the second mora is “flopped onto the following vowel-initial syllable. This creates an onset (hence a preferred syllable structure).” (Hayes 1989:258). This is all Hayes says about the mechanism of flopping. It is apparently conditioned by the fact that the following syllable is vowel-initial and that the preferred syllable structure is consonant-initial. Note that although Hayes uses the term ‘onset’, the onset has no formal status as a node in Hayes’ theory.

Note also that the mechanism of ‘flopping’ is different from normal onset formation in Hayes’ model. As we have mentioned above, normal onset formation is an instantiation of the autosegmental concept of dumping. ‘Flopping’ however is not dumping, because the element (the consonant) which is linked to the second syllable node is already linked to syllabic structure. Neither is it spreading, because the node to which the consonant is linked ( $\sigma$ ) is already linked to other elements. We will come back to the question of ‘flopping’ below in section 3, when we evaluate the merits of Hayes’ theory. For reasons that will become clear below we will refer to this type of ‘flopping’ as ‘simple flopping’ (as opposed to ‘double flopping’, to which we will come shortly).

## 2.2 ‘Classical’ compensatory lengthening

We now come to the processes of CL. The role of moras in CL is that they are preserved when the elements they dominate are deleted. Then, other,

nondeleted, elements can spread to them. An example is Latin *cānus* /kasnus/ → [ka:nus] 'dog' (a case of 'classical' CL (Hayes 1989:262)):

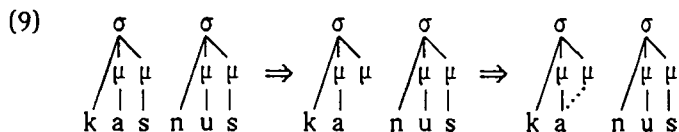

Apart from this 'classical' type of CL, Hayes presents other types. We mention a few of them here, as an illustration.

### 2.3 The 'double flop'

First, the 'double flop'. This term refers to CL phenomena where the loss of the onset of a syllable results in the lengthening of a vowel in the preceding syllable. Examples are the following forms in Ancient Cyrenaean and Ionic<sup>1</sup> Greek: \*ξενFος ⇒ ξηνος (*kse:nos* ⇒ *kse:nos*) 'stranger', \*ὄδFός ⇒ ὠδός (\**odwos* ⇒ *o:dos*) 'threshold'. The lengthening process resulting from the loss of the *F* (*w*) is usually classified by philologists of Ancient Greek (like Bartoněk 1966:68-70) as the third compensatory lengthening of Ancient Greek.<sup>2</sup> Of this process, Hayes gives the following account (1989:

<sup>1</sup> Hayes mentions that the form as shown here could be found in Ionic (his sources are apparently Steriade (1982:118) and Wetzels (1986:310)). However, as Buck (1955:49-50) and Lejeune (1972:82, 159) indicate, the forms *o:dos* (ὠδός) and *kse:nos* (ξηνος) are found in Cyrenaean (a Doric dialect), while in Ionic the forms are found as οὐδός and ξεῖνος respectively. The *ou* and the *ei* here indicate vowels (often transcribed as  $\bar{o}$ ,  $\bar{e}$ ) whose quality was more closed than the sound indicated by  $\omega$  [o:] and  $\eta$  [e:]. The *ou* in time became raised to *u:* in the relevant dialects (Lejeune 1972:230). The reason for the difference between  $\omega$ ,  $\eta$  and *ou*, *ei* is that in many dialects, (as Attic and Ionic) the omikron and the epsilon differed in quality from the omega and the eta respectively, the short vowels being more closed. As a result, the lengthened varieties of *o* and *e* retained the quality of their short counterparts and did not fuse with  $\omega$ ,  $\eta$  (Buck 1955:28).

<sup>2</sup> The process termed by Hayes as 'double flop' is by no means limited to the 'third CL'. It is also displayed by forms where the lengthening was the result of the loss of another consonant like in Attic-Ionic \*ἀγγελσαι ⇒ ἀγγεῖλαι (*angelsaj* ⇒ *ange:laj*) 'announce' (inf. aor.), Homeric (= Early Ionic) \*ἔκρινσε ⇒ ἔκρινε (*ekrinse* ⇒ *ekri:se*) 'judge' (3rd pers. sing. aor.) (Lejeune 1972:126-128) (see also Bubeník 1983:58, Steriade 1982:148 and Wetzels 1986:306).

266):

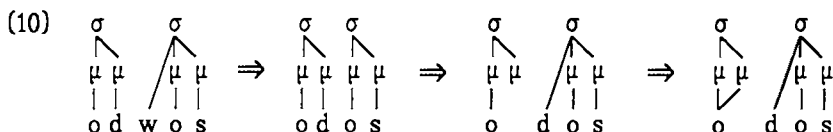

Here the *d* is detached from the second mora and is linked to the second syllable. Presumably, because the *d* cannot be a geminate in this dialect (Hayes remains silent on this point), the mora is emptied, and the vowel can spread to the mora, hence it is lengthened. The double flop differs from the 'single flop' in that the *d* is detached from the first syllable. Hayes does say why the 'double flop' occurs. He writes (p. 266) "when the /w/ deletes the /d/ desyllabifies, eliminating the highly marked syllable juncture *od.os*. The resyllabification empties a mora and allows the preceding vowel to lengthen." We could interpret this in two slightly different ways. Either the *d* delinks first and is then linked to the second syllable, or the linking to the second syllable is an independent process, identical to the 'simple flop' (see above), but which this time triggers the delinking of the consonant from the second mora of the first syllable, because the language in question does not allow for geminates (i.e., multiply linked consonants). Although Hayes is not explicit on this matter, the name 'double flop' seems to suggest the second possibility.

#### 2.4 CL through vowel loss

A third type of CL we wish to exemplify here as an example of the treatment of CL in Hayes' theory is CL through vowel loss. An example is the Early Middle English form [talə] which changed into [ta:l], Modern English *tale* (Hayes 1989:268, quoting Minkova 1982 and Hock 1986). After the deletion of the schwa dominated by a mora the principle of Parasitic Delinking takes effect. This principle reads (Hayes 1989:268): "Syllable structure is deleted when the syllable contains no overt nuclear segment." The effect of Parasitic Delinking on the output of schwa deletion process is as follows:

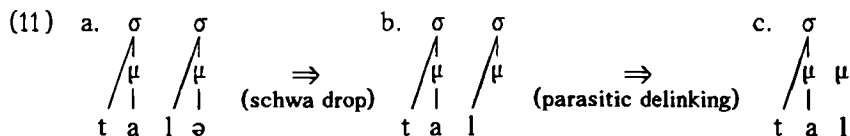

Note that the mora has been conserved, due to a stability effect. When the form in (11c) has been arrived at, the CL process of Middle English, which says “fill empty moras by spreading from the left” (Hayes 1989:269), takes effect. This results in the following derivation:

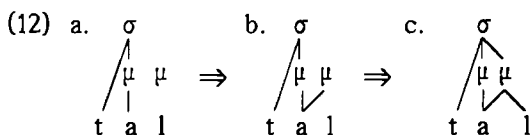

### 3. Criticism of Hayes' theory

So far the illustration of Hayes' theory. At this point a short and preliminary evaluation of the mora theory is in order. The advantages of Hayes' theory are at first sight twofold: (i) there is a direct representation of the syllable weight in the syllabic structure and (ii) the phenomena of CL can be accounted for easily. Hayes contrasts his theory on CL with theories involving other types of syllable structure and demonstrates that under the assumption of these types, one can just as easily derive nonexisting types of CL as existing ones. Therefore, these theories are devoid of explanatory power. This type of theory is termed 'X-theory' by Hayes, because the processes take place at the skeletal level. We will come back to this in a moment.

#### 3.1 The nature of the representation

Unfortunately, there are severe drawbacks to Hayes' theory. Let us first consider the nature of the multilinear structure Hayes uses. Since the type of representation Hayes uses is in fact a set of dominance relationships, one would consider his representation to be a metrical one. However, as we have seen, he also uses autosegmental principles like spreading and dumping. Therefore, one would think the representation is autosegmental. This leaves us with a question. Autosegmental and metrical representations



each have their own defining restrictions. In each of the subtheories, autosegmental and metrical, there are theory-specific notions which have received their motivation through these restrictions. Therefore, for both theories, we need to consider whether Hayes' theory complies with the respective restrictions.

### 3.1.1 Moraic syllable structure and autosegmental theory

Let us first consider Hayes' type of representation from an autosegmental point of view. To do this, we should investigate whether his representations in fact comply with the constraints of autosegmental phonology. One immediately notices a lack of congruence in the theory of mora assignment: while a syllable-initial consonant (or *onset* consonant, but note that the onset has no formal status as a node in mora theory) is directly linked to the  $\sigma$ -node, in the case of vowels there is an intervening  $\mu$ -node. This particular type of configuration has been devised, as we have seen, to express the fact that syllable-initial consonants do not contribute to syllable weight, while vowels (and sometimes postnuclear consonants) do, as well as to provide a medium, through the principle of moraic conservation, for the preservation of syllable weight (i.e., compensatory lengthening).

Hayes uses the mechanisms of spreading and dumping which have their motivation in autosegmental phonology, as a device for establishing links between elements on different tiers. In the autosegmental model, the multi-layered phonological representation is a metaphor for relationships between members of different ordered sets of elements. The ordered sets are the tiers which in themselves constitute linear sequences of elements (hence the ordered character of the sets). The relationships between members of the sets are the association lines between these tiers. One of the essential constraints which define autosegmental phonology is the constraint that if association of one element to another element takes place, this second element should be on an adjacent tier. Association cannot *skip* tiers on which elements are located and link elements which are in the same plane (or bidimensional space), but not on adjacent tiers. In other words, the restriction is that elements of a given set can only be linked with members of one other *single* set of elements above them and another *single*

set of elements below them. We call this restriction the principle of *planar tier locality*.<sup>3</sup>

In fact, planar tier locality is a necessary consequence of the idea of the plane. To see this, one should realise what happens if one makes it possible for an association line to go through a tier without being linked to an element on it. If one wishes to link three elements x, y and z which are on three different tiers in one plane, there is only one possibility if planar tier locality is to be obeyed, i.e. the configuration in (13a).

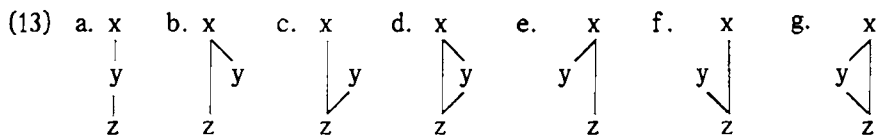

If, on the other hand, one does not wish to obey this principle, the representations in (13b,c,d,e,f,g) become equally possible. We see that the number of possible representations is septupled. Not without understatement perhaps, one could say that non-observance of planar tier locality makes the theory less restrictive. In fact, with this demonstration it is easy to see that if there is no requirement to be local for a link, the whole idea of tier ordering is meaningless and there is consequently no difference (in terms of possible relationships between elements) between a plane (a bidimensional space) and a space with an infinite (or more precisely: unspecified) number of dimensions.

A related problem is the one concerning the interpretation of the possible representations. If one drops the requirement of planar tier locality, e.g. the following configurations would be possible.



The only reason why these particular configurations do not occur is that Hayes' rules happen not to generate them. The configurations in (14) are,

<sup>3</sup> We owe part of this argument to Richard Wiese.

however, not ruled out in principle by any geometrical principle in Hayes' theory, and at least it should be possible to ascribe interpretations to (14a,b) (and also to representations of the type of (13b-g)). But it is totally unclear what the systematic phonetic interpretations of (14a,b) could be. In a theory which uses autosegmental principles, as Hayes' theory seems to do but which, in addition, obeys the principle of planar tier locality, configurations like in (14) cannot occur.

Planar tier locality, together with the prohibition of crossing association lines (perhaps the most fundamental principle of nonlinear phonology, introduced by Goldsmith (1976)), and the general principles of Euclidian geometry (only one line can be drawn between two points, lines cannot 'jump' one another) are defining properties of autosegmental phonology. If one does not obey them, the mechanisms of association, spreading and dumping in autosegmental theory become infinitely powerful. This is so, because then any element on any tier can be linked to any other element on any tier. If one accepts this as a possibility, anything goes and there are no restrictions on representations whatsoever (and there is no theory). As we have just seen, Hayes' theory, although it crucially uses the autosegmental mechanism of dumping, fails to obey planar tier locality.

### 3.1.2 **Moraic syllable structure and metrical theory**

As mentioned, Hayes' theory seems in fact also part of metrical phonology. One of the defining notions of metrical theory is the notion of hierarchy and, related to this, the notion of dominance (in autosegmental theory, only the notion of multilinear representation is crucial). But one of the results of the representation adopted in Hayes' theory, in conjunction with the fact that autosegmental conventions like spreading and dumping are operational in syllable structure in this theory, is that the notion of dominance has become meaningless.

To see this, recall from the previous subsection the fact that in this representation planar tier ordering is not obeyed. As a result, by the working of the association conventions, or by the application of a rule, it is possible to link any element to any other element through any element in the same plane, regardless of the intervening tiers. This situation is intolerable for



foot symbol ( $\varphi$ ) dominating the tree), and not as in (16), which is an ill-formed structure in Hayes' (1981,1982) theory:

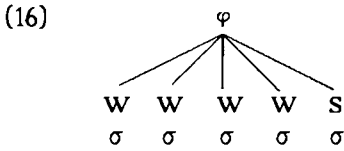

Binary branching is in fact the expression of the idea of *relative strength* of elements with respect to each other on a given tier. Let us now look at syllable structure again. Hayes (1989:269,277,292) assumes the following structures for syllables starting with more than one consonant:

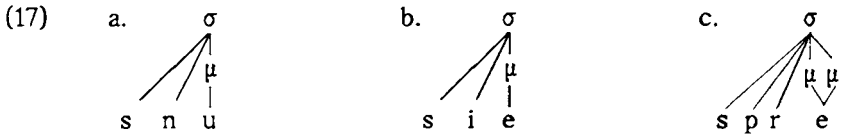

The *i* in (17b) is interpreted as a glide because it is not dominated by a mora (cf. (3a)) (the example is from the putative<sup>5</sup> Middle English form [pasjens] ⇒ [pa:sjens] (Modern English [pejʃəns])).

The *n*-ary branching here is a result of the syllabification model chosen by Hayes. This syllabification model, which lacks intermediary nodes, through which binary branching can take place, is itself the result of the fact that no difference is made between subsyllabic nodes and moras. If one does assume branching nodes below the level of the syllable for onset consonants, this means that one has to identify which nodes contribute to weight, and which do not. The direct representation of syllable weight in geometrical terms, which as we have seen is one of the advantages of Hayes' theory, would be lost. In fact, we would be back in the same old situation in which one had to state that certain nodes (e.g. the onset (= the branching node before the mora)) do not contribute to syllable weight, while elements dominated by the other nodes, like nucleus and coda (or rhyme) do.

It has to be concluded that Hayes' theory obeys the defining properties

<sup>5</sup> See section 4.8 (below) on the working of CL in the word *patience*.

and restrictions of neither autosegmental nor metrical theory. This leaves us with the question of what the defining restrictions on representation of his theory are (if there are any). Unfortunately, we cannot answer this question, since Hayes does not provide us with any further theoretical basis. We are therefore forced to conclude that Hayes (1989) uses notions of autosegmental and metrical theory that, because they have been taken out of their theoretical context, have no motivation.

### 3.2 The principle of moraic conservation

There is a second major point on which Hayes' theory violates the basic assumptions of metrical theory. As we have seen in CL by vowel loss (cf. (11)), the mora continues to exist, although the element which it dominated *as well as* the element it was dominated by, have been deleted. It is peculiar that this element continues to exist, while a higher element, the syllable node, *in the same dominance structure* is deleted as a result of the deletion of a lower element, the segment (as a result of parasitic delinking).

Therefore, one could ask why the mora does not undergo parasitic delinking as well in this case, just as the syllable. This question in fact remains unanswered: 'moraic conservation' is vital to the theory, but is not needed for any other phenomenon than CL. It is therefore not independently motivated, and is just an axiom needed in the theory. We will come back to this question in section 3.5, when we take a close look at Minkova's (1982, 1985) accounts of CL through vowel loss.

### 3.3 High vowels and glides

Another interesting point is the behaviour of high vowels and glides. As was mentioned in the introduction, one of the drawbacks of Hyman's theory reported by Odden, is the fact that there can be no contrast between two otherwise identical elements in the same environment. This was remedied by Hayes through allowing syllabic segments (e.g. high vowels) to be dominated by a mora underlyingly, while he assumed that corresponding nonsyllabic elements (e.g. glides) are not dominated by a mora. This, however, has other, but related, undesirable consequences. Although in many languages,

one can observe a contrast between syllabic segments and corresponding non-syllabic ones in the same environment, perhaps the more normal case is that there is an alternation in syllabicity of the segment type in question, conditioned by syllable structure. Thus, normally, a high vowel in front of a non-high vowel will become a glide. In order to account for this state of affairs, Hyman developed his universal Onset Creation Rule (given in (1), above). A drawback is that there is a fair number of exceptions which cannot be accounted for, because it is claimed that the rule is universal. The change made by Hayes makes it indeed possible to account for otherwise identical segments to be syllabic or nonsyllabic in the same environment. But in the majority of cases, the choice of the realisation of a segment as a high vowel or as a glide depends on whether the segment is in prevocalic position or not.

For these cases, Hayes cannot account. To account for them, one would have to devise a rule that deletes the mora from an underlying element (assuming that it underlyingly bears a mora, as a high vowel would do), or one that adds a mora to an element (e.g. to a liquid when this liquid becomes syllabic under certain conditions). If one posits that these rules are universal, we are back to the original problem pointed out by Odden, namely that (i) there are certain languages which do not obey these rules and that (ii) certain forms in certain languages do not obey these rules, whereas otherwise they do obey the rules.<sup>6</sup> In fact, Hayes seems not to have really solved the problem noted by Odden.

### 3.4 Spreading and 'flopping'

There is another problem concerning glides. Although the notion of spreading plays a crucial role in the account of CL in moraic theory, other apparent occurrences of this mechanism cannot be accounted for because the

---

<sup>6</sup> This latter situation is found in French, where there is free alternation between high vowels and homorganic glides, if a postconsonantal high vowel is in hiatus position, e.g. *lier* [lie] ~ [lje] 'to bind', *l'ouest* [lwest] ~ [lwɛst] 'the West'. In certain words, however, especially of foreign origin, the element in this position is always a glide (and as such does not trigger the deletion of schwa in the article *le*) e.g., *le yaourt* [lə jaur(t)] 'the yoghurt' (see Kaye & Lowenstamm 1984: 135ff).

node to which spreading should take place is lacking. A clear case is the spreading to onset position. An example is the apparent insertion of a homorganic glide after a high vowel followed by a heterosyllabic vowel in many languages (Dutch, English, French, German, just to mention a few) in a word like *piano*. In a theory involving full subsyllabic constituents, the spreading can be described in a fully autosegmental way:

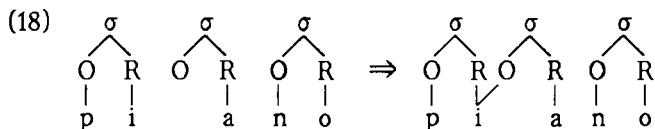

In Hayes' theory, this would have to be accounted for by the syllabification rule of adjunction of prevocalic consonants (mentioned above):

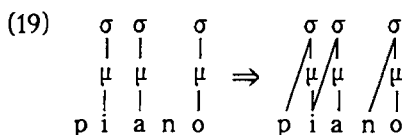

Because the *i* is adjoined to the following syllable node and is not dominated by a mora which itself is dominated by the second syllable, it is realised as *j* in this syllable (cf. (3a)). In this way, the high vowel functions in a way identical to the geminate *n* mentioned above (the (single) 'flopping' case, see (8)). This is the moment to take a closer look at 'flopping'.

In fact, the mechanism of 'flopping' receives no motivation at all in Hayes' theory. All that is said about this is that it takes effect if there is a following vowel-initial syllable (1989:258). "This creates an onset (hence a preferred syllable structure) ..." (ibid., italics ours). Although Hayes identifies the reason for this linking, he cannot in effect achieve this by spreading, since the onset is not a node in the syllable geometry he proposes. Hence he has to invoke flopping in a teleological way: it "creates an onset, the preferred syllable structure" (ibid.). If onset is a genuine node, the reason why the linking takes place is independent of any 'goal'. In fact, 'flopping' is not a general principle and will therefore have to be stated as a rule (although Hayes does not formulate one).

Whereas 'flopping' is a specific rule, in a theory where empty onsets are



genuine nodes (and not just mnemonics for potential geometrical configurations), it can be replaced by a general spreading process (here spreading of the glide to the empty onset). In contrast to 'flopping', spreading is the result of a general convention, and need not be stated as a separate rule for this specific occasion. Because it is an instantiation of a general convention, this linking (which here boils down to glide formation) provides us with insight as to why it actually takes place.

The drawbacks of the moraic model of the syllable in this respect become even more apparent if one looks at an alternative to this type of glide formation, viz. glottal stop insertion. If there is no high vowel available for spreading to onset position, a default consonant may be inserted into an empty onset position,<sup>7</sup> which is often a glottal stop. Consider the word *Theater* in German, which may be pronounced as [tʰe:ʔa:tɐ]. The mechanism of default value assignment is one of the basic conventions of autosegmental phonology, as developed by Goldsmith (1976) and others. Pulleyblank (1983) has shown that spreading of an adjacent element (originally this was limited to tones) is not always automatic, and may be replaced by default value assignment. This means that the neutral value is assigned to a specific position. For onsets, we can assume that the default element assigned is the neutral consonant, which is often a glottal stop:

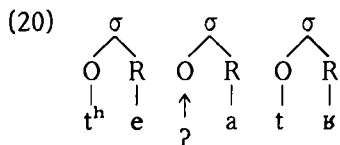

In a moraic model of the syllable, a specific rule would have to be devised. Because this rule would have to be specifically stated, the fact that the processes of glottal stop insertion and of high vowel spreading are comple-

<sup>7</sup> In Dutch there is also spreading if the left vowel in a hiatus is a mid vowel. Hence *theater* in this language is pronounced with a glide: [tɛːja:tɛ]. If one adopts the idea that the glottal stop and the glide in this position are indeed the result of the workings of two competing mechanisms, instead of idiosyncratic rules, the difference between the two closely related languages becomes a minor one. This is what one would expect in the first place. Under the moraic model of the syllable, however, the difference between the two languages is considerable.

mentary is not accounted for, while it is accounted for in the constituent model of the syllable, because both are conditioned by the empty status of the onset. In addition, this rule would be of a complex nature: a glottal stop would have to be inserted in intervocalic position *and* would have to be adjoined to the second syllable.

### 3.5 Ignoring arguments for a foot-based account

Having discussed the theoretical basis of Hayes' theory, we must now say a word about its empirical basis. For this, recall from section 2.4 the CL through vowel loss (*talə* ⇒ *ta:l*) which occurred in Middle English. This kind of CL is well attested for many languages, but not exactly in the way as Hayes suggests. Arguing against the general idea that there was simple open syllable lengthening in Middle English whenever this syllable was stressed, he states that Minkova (1982) "who took the trouble to collect all the forms of early Middle English that have undergone the rule" stated the "real generalization which holds for 97% of the relevant cases", which would be that "a stressed penult in an open syllable lengthened just in case a word-final schwa was dropped" (Hayes 1989:266).

If one takes the trouble to look for oneself and see what Minkova has actually written, a slightly different picture emerges. Hayes is correct in stating that the lengthening process should be concomitant to the deletion of the vowel in the following syllable. But it turns out that there is a second condition: "MEOSL [Middle English Open Syllable Lengthening] affects only *fully stressed disyllabic* words, and we can think of them as major class words. In terms of *rhythmic organization* this would mean that the first light syllable will in all likelihood be a *foot-initial* syllable" (Minkova 1982: 48, italics ours). Words of more than two syllables were not affected by MEOSL. Hayes fails to mention this important detail.

The reason for this second condition is, according to Minkova, metrical: more specifically it is foot-based. "Phonologically, the syllable affected must be characterized as 'weak' rather than 'open'. [...] The lengthening of the short vowel should be attributed to the principle of preservation of the overall rhythmical weight of the foot" (Minkova 1982:51). In a later article (Minkova 1985), not discussed by Hayes (1989), Minkova elaborates and

formalises her theory. She refers to Giegerich (1981,1985), Nakatani and Shaffer (1978), O'Connor (1973) who all mention (in different ways) "that monosyllabic lexical items are distinguished from the syllables stressed or unstressed, of polysyllabic words in terms of greater duration" (Minkova 1985:169, quoting Giegerich 1985:12). She then says (1985:170) that the answer must lie in "the principle of phonological isochrony in stressed-timed languages as English." The only option for a monosyllabic foot to achieve durational parity with other, polysyllabic, feet is to lengthen the syllable.

She postulates that the well-balanced foot in English has the form [S W (W)]. She explains the fact that forms of more than two syllables were not affected by syllable lengthening as follows: "Though schwa was lost in words of three and more syllables, the resulting structures were well-balanced [S W (W)] metrical frames: there was no significant change in the category of foot type" (1985:173). Monosyllabic forms resulting from vowel loss like in *talə* ⇒ *ta:l* underwent the lengthening in order to conform to the well-balanced metrical frame. In fact, for the same reason, not only monosyllables resulting from vowel loss, but *other* lexical monosyllables also underwent this vowel lengthening. Monosyllabic forms imported from Anglo-Norman like *peak*, *boot*, *coat*, *gout*, *gown* also got lengthened once they became part of the Middle English lexicon (1985:166,174). Furthermore, this lengthening has also taken place in Late Old English words like *wēl* 'well', *wēr* 'man', *bēt* 'better' (1985:173).

Minkova assumes that feet dominate syllables, syllables rhymes, rhymes syllabic peaks, peaks segments. Under her theory the change took place as follows (1985:171):

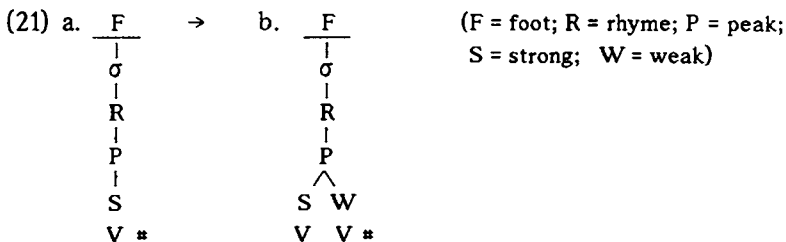

The process depicted in (21) is the result of the fact that the foot structure

in (21a) was 'imperfect'. This "calls for a change down the ranks; [...] the 'orders' for change percolate down to the peak level, where 'strengthening' takes the shape of branching" (1985:171) (we will return to this idea in section 3.7, where we present the treatment of CL through vowel loss in our own model).<sup>8</sup>

The process was undergone by originally monosyllabic words of Anglo-Saxon and Anglo-Norman origin, and by monosyllables that had arisen from vowel loss. Additional motivation for this foot-based analysis is that nonlexical, words like *have*, *were*, *are* which were also subject to schwa loss, did not undergo the lengthening. "They will not normally constitute feet in isolation and will therefore be ineligible for readjustments following schwa loss" (1985:173). Apart from these arguments there are more arguments in favour of a foot-based account in Minkova's (1985) paper. It would lead us too far astray to reproduce them here, but we feel that the ones presented above are convincing enough.

Hayes does not provide the reader with an explanation as to why he chooses to ignore the arguments in favour of Minkova's foot-based account. In contrast to a foot-based account, his analysis cannot explain why (i) words of more than two syllables and (ii) function words like *have*, *were*, *are* do not undergo the lengthening. Neither does it explain the lengthening of originally monosyllabic words, to which the CL through vowel loss in Early Middle English seems clearly related.

With Minkova's analysis, we can safely assume that the rhythmic organisation is responsible for the lengthening phenomenon. Rhythmic organisation in fact cannot be expressed within the syllabic structure. It seems that the CL is here not the result of moraic conservation, but of a *minimal foot quantity requirement*.

Note that the idea of foot conservation is much more straightforward than that of moraic conservation: we have seen above (section 3.3) that moras were conserved although the material they dominated (segments) as

---

<sup>8</sup> The final *l* in the newly formed foot of *ta:l* does not contribute to syllable weight, according to Minkova because the language does not allow gemination. This supposes that gemination indicates whether adjunction of a consonant to a syllable ending makes a syllable heavy. A more straightforward explanation is that a word-final consonant is extrametrical.

*well* as the material they were dominated by (the syllable) had been deleted. We also mentioned that this fact, i.e., that moras are not subject to parasitic delinking, is an otherwise unmotivated axiom of Hayes' theory. If CL through vowel loss is the result of foot conservation rather than of mora conservation, one does not run into problems like this. We do not have to state idiosyncratically that feet are conserved and do not undergo Parasitic Delinking because they are not eligible for parasitic delinking in the first place: they are still dominating material other than the material just deleted. Lengthening takes place because the quantity of this material does not suffice for the foot in question to meet minimality requirements.

As mentioned, Hayes cannot account for the fact that the lengthening takes place only in disyllables. Hayes refers to Hock (1986)<sup>9</sup> for examples of the same type of CL in Balto-Slavic, Hungarian, Jutland Danish, Korean, various dialects of German, as well as the Slavonic languages. If one looks at the examples adduced by Hock (1986:435-438), one sees nothing that contradicts a metrical foot analysis for this type of CL, while, as we have seen, there is evidence against an analysis where moras are integral part of syllable structure.

Because Hayes cannot limit the working of CL to disyllables in his theory and cannot exclude the CL from operating in function words like *have*, *were*, *are*, his proposal suffers in fact from the same flaws as Streitberg's (1893, 1894) law for Indo-European (of which in the relevant respect it seems a modernised edition). This law reads 1893:30):

---

<sup>9</sup> Hock (1986) argues against Clements' (1982,1986) treatment of CL in the latter's framework of CV-phonology. Hock argues in favour of an autosegmental treatment of CL, where a mora has the role of an autosegment. He does not, as Hayes does, propose that the mora is a building stone of the syllable. Apart from the type of CL illustrated by the Middle English case *talə* ⇒ *ta:l*, and CL through glide formation (see section 2.4.7) (both of which are metrically based), in our framework not moras, but the subsyllabic nodes assume an autosegmental role in CL (in that spreading takes place to them, see the next section). Our framework also differs fundamentally from Clements' in that spreading does not take place to elements (i.e., Clements' C's and V's) whose nature and number are a function of the segments, but to subsyllabic nodes like onset, nucleus, coda), whose nature and number are determined by the syllable assigned by the syllabification mechanism.

Schwindet eine akzentlose Silbe, so wird ein vorausgehnde Silbe zirkumflexiert, wenn sie lang, gedehnt wenn sie kurz ist.

("If a syllable not bearing the accent disappears, a preceding syllable becomes circumflex if already 'long' and 'long' if previously 'short'.")  
(Translation by Collinge 1985:181).

In fact, Streitberg lists the same reason as Hayes, though slightly differently formulated. The reason for the process is "Morenverlust" ('mora loss') (1894:313). He seems to use Fick's concept of mora replacement (see Collinge 1985:181). Streitberg's law, because it has been found inapplicable in many cases, has received little attention. In fact, it is purely based on Proto-Indo-European reconstructions. All attested occurrences of effects of the law were heavily disputed: "what happens after the PIE period is either irrelevant [...] or even contradictory to the law. [...] Not surprisingly, Streitberg's law is well out of the limelight these days" (Collinge 1985:182). Indo-Europeanists could of course not foresee its (forseeably) short-lived resurrection.

We end this main section with the conclusion that Hayes' theory has some doubtful theoretical consequences, especially concerning the nature of possible representations. On top of that, with the observation that Hayes cannot account in a principled way for the syllabically conditioned change in syllabicity in certain environments, it can be said that his theory contains some empirical inadequacies. Thirdly, one of the types of CL, which Hayes presents as one of the main motivations for his theory, turns out to be conditioned differently from the way suggested.

Apart from the criticism raised in this section we will criticise the idea of flopping (exemplified above in (8) and (10)) in the next section.

#### 4. Comparison with a true constituent model of the syllable

As mentioned, Hayes only compares his theory with a syllabic theory in which the skeleton and not the subsyllabic constituents has a role to play in CL. He argues that his theory is more restrictive. More specifically, he shows that two types of CL which, under "X-theory", would be predicted to occur and which do not, are effectively excluded by mora theory. We will now review these cases and show that a concept of the syllable in which

onset, nucleus and coda are genuine nodes and not just mnemonics for a specific type of branching, also exclude this type of CL phenomena. Then, we will review the catalogue of CL types which Hayes lists in his typology, and show that the constituent model can effectively account for these cases. But first we will give a synopsis of a true constituent model of the syllable.

#### 4.1 Syllable geometry and the syllable assignment theory

In Noske (1989,1992) we proposed that syllabification is the *imposition* of syllabic structure onto a string of segments. According to the languages and depending on other things (to be treated below) the syllable is bi- or trinodal, cf. (22):

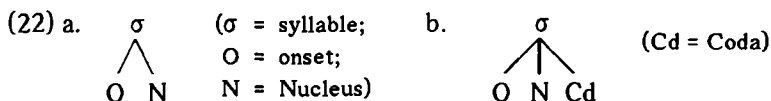

The nodes onset, nucleus and coda have been taken as mnemonics only. What is important is that a syllable is either bi- or trinodal. The links between the segment (or better: skeletal slots) are established by the normal association conventions of autosegmental phonology which were originally devised for tones only.

In Noske (1989:132;1992) we argued further that the autosegmental association conventions of *mapping*, *dumping*, *spreading* and *default value assignment*, originally developed by for tonal phenomena, also play a role in syllabification. In order to let the association conventions do their job in syllabification, the role of the tone in the association conventions should be assumed by the segment (or skeletal slot) and that of the Tone Bearing Unit by the subsyllabic constituent like onset, nucleus and coda. The syllabification takes place as follows (Noske 1989:132;1992):

#### (23) *Syllable assignment theory*

The string of segments is scanned for nonsyllabified segments in a directional way (RL or LR). If a nonsyllabified segment is encountered, a syllable of the canonical shape is superimposed onto the

string of segments. Then, optimal linking between the segments and segment bearing units takes place, according to the general conventions of autosegmental phonology. Then the scanning process begins again, etc.

The 'canonical shape' of the syllable is dependent on the language in question. Some languages only impose binodal syllables, others only trinodal syllables. In yet other languages the choice is dependent on the type of segment encountered during the scanning process.

By positing the 'flat' syllable structure as in (22b) for a trinodal syllable, instead of a structure where there is a rhyme node which subdivides into nucleus and coda, we are able to comply with the requirement of planar tier locality (a notion outlined in section 3.1.1), to which this model is subject because it is autosegmental in nature.

This summary of the model suffices for present purposes. For more details and a full motivation of the model, see Noske (1989,1992).

#### 4.2 Classical CL in the true constituent model

We will now show, by way of illustration, how the most straightforward and non-disputed type of CL is accounted for in the constituent model. This type, 'classical' CL, concerns cases like (9), Latin *kasnus*  $\Rightarrow$  *ka:nus*. The deletion of the *s* in the first syllable takes place as in (24a). We are then left with the structure as in (24b), in which there is spreading to the coda from the vowel to its left.

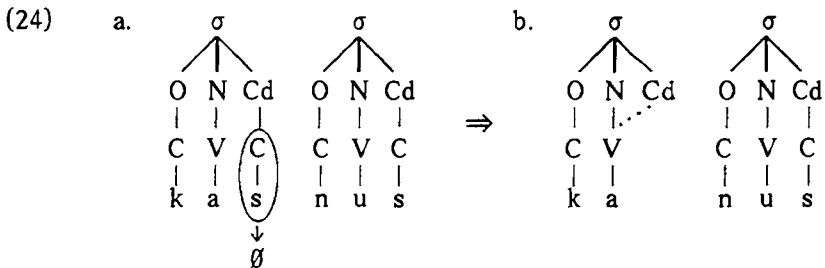

Hence CL is here the result of the application of the spreading convention. Note that this operation of the autosegmental conventions is perfectly



natural: since they are needed for syllabification between the same levels, it need not be stated just for this case of CL that they are operative here. Quite to the contrary, it would have to be stated as an idiosyncrasy if the conventions were not operative anymore after they had performed their role in syllabification.

### 4.3 Progressive and regressive assimilation as CL

We will now treat other types of CL and show how they can be accounted for by the same model. First, progressive and regressive assimilation of consonants. Schematic examples are given in (25) (from Hayes 1989: 279):

- (25) a. asta ⇒ as:a                      b. asta ⇒ at:a

This type of CL can be easily accounted for in the true constituent model:

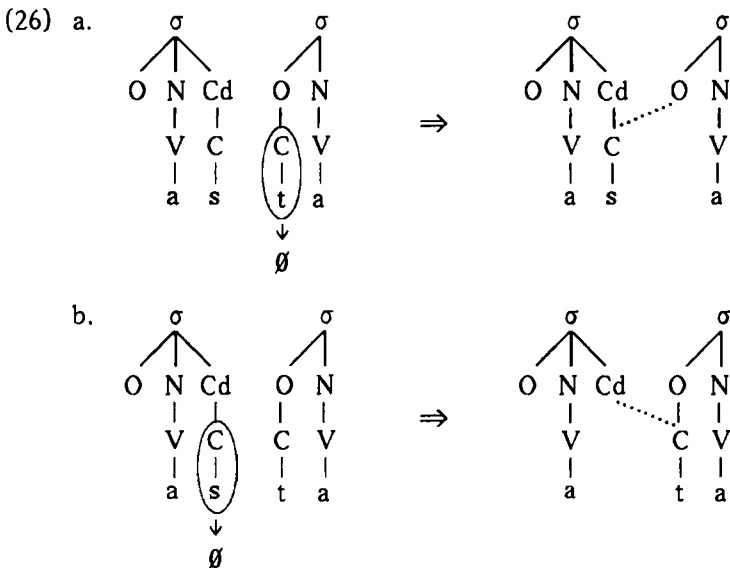

In fact the progressive assimilation (25a) can be accounted for more easily than under Hayes' theory. In our theory it is simply the result of a spreading operation (after deletion, the onset node is left empty, hence spreading from the C dominating s to the onset node can take place. In Hayes' moraic

theory, however, the spreading of *C* dominating *s* to the following syllable cannot easily be accounted for, because there is no onset, and hence no empty node after deletion of the *C* and the *t* it dominates.

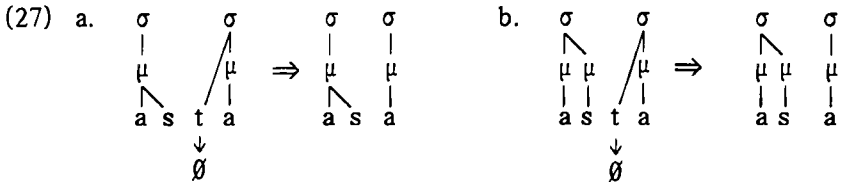

In (27a) we see the case where the *s* is not counted as heavy, and (27b) represents the case where it does count as heavy, hence has received a mora by virtue of the Weight by Position rule (6). Although Hayes does not mention this explicitly in this case, the mechanism of ‘flopping’, mentioned in section 2.1 (see (8) and (10)), would have to be invoked in order to let the *C* dominating *s* link to the following syllable:

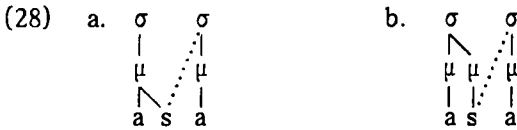

We have seen the theoretical drawbacks of ‘flopping’ in section 3.4.

The case of regressive assimilation presents no such difficulties in Hayes’ framework (or in ours as shown in (26b)). It can be accounted for straightforwardly, provided the deleted consonant is linked to a separate mora:

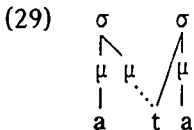

#### 4.4 Inverse CL

The case of regressive assimilation is parallel to ‘inverse’ CL (Hayes 1989: 280). Cases like these are found in Luganda (Clements 1986) and in Pali (Hock 1986:441):

(30) a. aika  $\Rightarrow$  akka    b. a:ka  $\Rightarrow$  akka    c. ila  $\Rightarrow$  lla    d. pila  $\Rightarrow$  plla

The latter two cases, which occur in Luganda and other Bantu languages, are interesting in the true constituent model, because here spreading does not take place to the third position, the coda, but to the second position, the nucleus, which is here part of a binodal syllable structure.

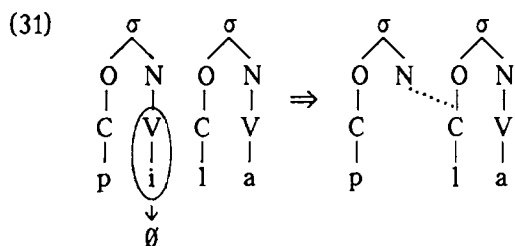

#### 4.5 The 'double flop'

The next type of CL is the type which Hayes terms the 'double flop'. We have already shown how this type of CL is accounted for in the moraic model (see (10)). There too, the teleological notion of 'flopping' was involved. In the true constituent model, instead of a specific rule, the general mechanism of spreading can be invoked:

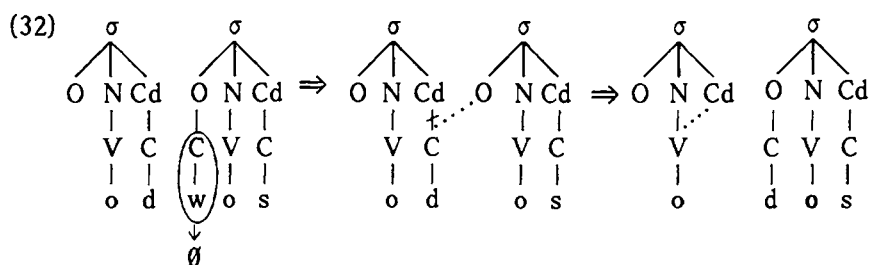

In (32), the *C* dominating *d* spreads to the onset, because an intervocalic *d* must be linked to the second onset. Geminate *d*'s are not found in Cyrenaean and Ionic Greek (in contrast to Boeotian, Thessalian, Elean, Cretan, Lacedonian and possibly Megarian (Buck 1955:71)). It may be hypothesised that this sequence is forbidden and that as a result the *C* is automatically

delinked from the coda of the first syllable.<sup>10</sup> This coda is now open for spreading from the V-slot. Thus, what we see is a sequence of spreading, delinking, spreading. Hence we propose to rebaptise this type of CL as 'double spreading'.

#### 4.6 CL through prenasalisation

Yet another type of CL is CL through prenasalisation. Hayes (1989:280) points out that this type of CL is widespread in Bantu languages. He refers to Odden (1981) and Clements (1986). It takes place as follows (*mb* represents a prenasalised stop):

(33) am ba ⇒ a: *mb*a

This type of CL can be accounted for in both theories. In the true constituent model the *m* fuses with the *b* in that it becomes dominated by the same skeletal slot). The skeletal slot which has been unlinked deletes by Parasitic Delinking, and the coda position to which the skeletal slot was linked is open for spreading from the skeletal slot dominating the first vowel. In the moraic model, the *m* is linked up to the second syllable (or, possibly, also fuses with the *b*, although it is not clear how), and the emptied mora is open for spreading from the *a*.

---

<sup>10</sup> Delinking did not take place in certain dialects (like Thessalian and Lesbian) for certain consonants. Therefore, instead of vowel lengthening, consonant doubling took place: ξενφοϛ ⇒ ξενφοϛ (ksenwos ⇒ ksen:os) 'stanger' (Buck 1955: 49-50, Sheets 1974:40ff, see also Wetzels 1986:304). Interestingly, Sheets (1974: 42) relates this to a postulated difference in the direction of syllabification, which distinguishes the Aeolic dialect group (to which Thessalian and Lesbian belong) from other Greek dialects, basing this on a difference in the stress system noted by Meister (1882:31ff). Meister writes "Die (sc. antiken, R.N.) Grammatiker berichten einhellig, die Äoler seien βαρνωχοί gewesen, d.h. sie hätten die letzte Silbe der Wörter nicht betont." ('The (sc. ancient, R.N.) grammarians report unanimously that the Aeolians were βαρνωχοί, i.e., they did not stress the final syllable of a word.') Although present theories do not link directly the nature of stress patterns and the direction of syllabification, there may nevertheless be such a link. This question is certainly a point for future joint philological and theoretical phonological research.

#### 4.7 CL through vowel loss

Two other types of CL listed by Hayes cannot be explained readily in the true constituent model by a reshuffle of the association lines between the skeletal and the constituent tier, as in the previous examples. The first type is CL through vowel loss. This type is exemplified by Early Middle English  $talə \Rightarrow ta:l$ ; the account in Hayes' theory was given above in (11) and (12). Recall from section 3.5 that Hayes' interpretation of the facts is wrong. As pointed out by Minkova (1982,1985), the lengthening is the result of a requirement of minimal foot quantity rather than of the number of moras. The true constituent model cannot explain this type of CL, as Hayes portrays it, by a reorganisation of the links between the skeletal units and the syllabic constituents. This is fortunate, as this type of CL does not take place in this way. This shows that our model is restrictive where it should be.

We should then ask how the minimal foot quantity requirement can be integrated in Hayes' model. The crucial question is here how feet are linked to moraic structure. The normal assumption here would be that foot structure is linked to the syllable nodes. In the case of  $talə \Rightarrow ta:l$ , however, the syllable node dominating the schwa has ceased to exist, due to parasitic delinking. As a result, the foot which contained this element would not possess the amount of phonological quantity required for its existence anymore. Since the syllable through which the foot was linked to the quantity element is deleted, extra syllable weight is imposed on the syllable to which the foot is still linked ('downward percolation' in Minkova's (1985) terms (see (21) in section 3.5, above). Since it is the foot, not the mora, which drives this process, this itself is not a reason to assume that syllable weight is encoded through moras rather than by any other means. It seems that precisely because of this, Hayes has chosen to ignore the fact that CL is foot-based here.

Another possibility would be to assume that feet are *directly* linked to moras in another plane, as in (34) (the lines cross each other only on this paper).

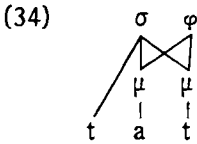

In this case, there would not be a uniplanar structure above the moras. There would be two planes, each with a dominance structure of its own, with moras as shared elements. The prosodic dominance would go from the moras directly to the feet. In addition, there would be a 'side-plane' from the moras to the syllables. Hence, syllables would not be part of prosodic structure anymore. It is, in fact, totally unclear what the role of the syllable would be, other than a node to which to attach onset elements. We have seen above that for reasons of geometrical definition, this is very problematic, due to the multiplication of possible planes. But apart from this problem, the only reason to do this is the fact that they do not count as a quantity element. This is in fact a (negative) *prosodic* reason. Thus, paradoxically, the (only) reason for the existence of a separate plane apart from the prosodic one is itself prosodic. Therefore, the postulation of a separate plane in this case would only serve to express that prosodic theory cannot explain the fact that onset consonants do not contribute to syllable weight. With much less fuss, one could just plainly state this fact.

There is yet another, very compelling argument against such a structure. If moras were not linked to the syllable node, the material in a syllable could belong to different feet, cf. (35a):

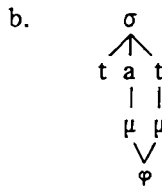
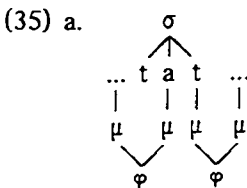

This would go against basic assumptions of metrical phonology. If a language has, e.g., left-dominant bimoraic feet, the *t* in the syllable in (35a) would have to be strong and the *a* weak. In the same language, however, a syllable like the one in (35b), where the prominence relationship between the two segments has been reversed, could not exist. No languages have

been attested where otherwise identical syllables are distinctive in the metrical prominence of their constituting segments.

It has to be concluded that Hayes' model cannot cope with foot-based CL, because one would have to make assumptions which would render his theory meaningless (or tautological to the facts). The model is not capable to account, in a straightforward geometrical way, for the process of foot-based CL.

The question then is how the conservation of foot structure should be expressed in our or any theory. While we do not wish to give a full account here, we do want to indicate a possible solution. It seems that higher prosodic nodes sometimes *induce* a certain quantity of elements. As we have seen in section 3.5, this is precisely what is proposed by Minkova (1985). It is well known that in certain languages certain categories of morphemes and words should contain a minimum number of syllables (for this, see McCarthy & Prince 1986:12-44). If a base form does not comply with the quantity requirement, a number of elements is simply imposed, just as in our model of syllabification subsyllabic constituents are imposed. It could be hypothesised that quantity information in the foot comes into existence by *derivation* from syllabic structure. If a syllable is deleted and hence a mismatch has arisen between foot quantity information and syllable structure, the syllable structure will be *minimally* modified to acquire concordance in quantity between syllables and feet. If there is a lack of quantity in the syllabic material a certain foot dominates, it will first be attempted to lengthen a syllable. If this is not possible, e.g., if a syllable is already long (or heavy), then an additional syllable is imposed. In the case of Early Middle English *talə* ⇒ *ta:l*, the first solution was possible.

The idea outlined here has the advantage that through the concepts of match and mismatch, no choice has to be made between a bottom-up model and a top-down model of structure building and adaptation. Clearly, operations in both directions are at issue here.

In fact there is no alternative to a derivative model of syllable weight (i.e., weight information is *derived* from syllable structure, and is not a primitive of it) such as the one outlined here, because of the fact that, as mentioned above, the information of quantity will have to pass through the syllable node (see (35)). It is possible to use moras in such a model, but the

process of CL through foot conservation as such does not provide support for the existence of moras. And, as we have seen there are several objections against the moraic model of the syllable independent of this type of CL.

In the case of  $tal\bar{a} \Rightarrow ta:l$ , the approach has an added advantage over Hayes'. Recall from section 2.4 (forms (11), (12)) the way CL takes place in this case:

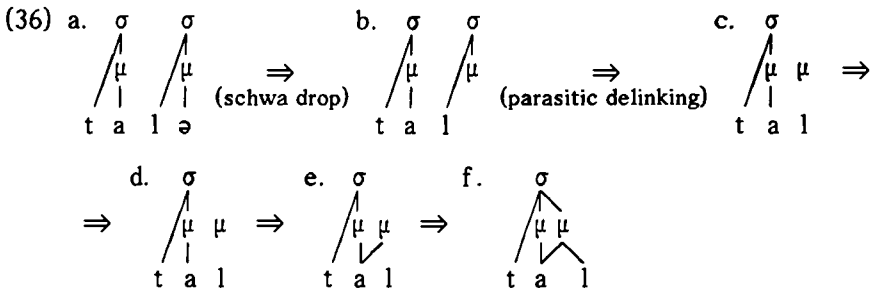

The question can be raised here why in (36d) the *l* does not link to the empty mora, but spreading of the *a* to this mora takes place first. The reason would be “Itô’s (1986) principle that syllable structure (indeed, all prosodic structure) is created maximally” (Hayes 1989:269). We fail to understand what exactly is meant by “maximal creation”. In fact, Itô (1986) does not use the concept of maximality, contrary to Hayes’ suggestion.<sup>11</sup> But Itô (1989) does use it. She writes (1989:219): “The maximality principle holds that ‘units are of maximal size within the other constraints of their form’ (Prince 1985).” Then the discussion continues regarding matters such as the necessity of constructing disyllabic feet whenever possible. Cases like the one in (36) cannot be subject to this principle. It is easy to see why. In a language where CVC syllables count as heavy, and which allows for long vowels, syllables like (37a) (*tal*) could not exist; they would necessarily be of the form in (37b) (*ta:l*). Yet, languages of this type usually abound in syllables like *tal*.

<sup>11</sup> Hayes does not provide the reader with a page reference as to where the concept of ‘maximality’ could be found in Itô (1986).



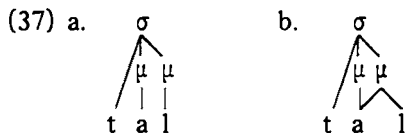

The question can be raised why Hayes has to make use of this peculiar interpretation of the concept of maximality. The relevant case in Early Middle English seems to be one of foot conservation. Apparently, the formation of a syllable *tal*, without a long vowel, did not satisfy the quantity requirement of the preserved foot. Therefore it can be assumed that CVC syllables do not count as heavy in Early Middle English. By contrast, a CVV syllable does, as does a CVVC syllable. Therefore, by way of the matching principle, a CVV syllable is created, by the lengthening of the vowel (in our model, by the creation of a right margin node). The *l* is subsequently linked to the coda node, probably as a result of a genuine principle of maximality (which says that no node or element may stay unlinked if it can somehow be linked).<sup>12</sup>

Hayes' theory cannot express the relationship between the fact that a CVC syllable counts as light and the idea of the quantity preservation. This is so because he does not have a statement in the phonological grammar saying "CVC syllables are not heavy." The fact that CVC syllables do not contribute to weight is explained in his theory by the assumption that there is no Weight by Position rule, which works during syllabification, in the language in question. Hence the fact that CVC syllables do not count as heavy is simply not available as information at the moment of the application of CL. The reason is the direct relationship between moras and syllables.

In a theory where, in contrast to Hayes' model, there is an derivational interface between syllable structure and the expression of weight, this in-

---

<sup>12</sup> Note that the crucial difference between this kind of maximality and the one apparently invoked by Hayes is that not the number of links should be maximal, but that a maximal number of nodes (on whatever level) should be linked. This means that the fact that disyllabic feet are created wherever possible is the result of the requirement that a maximal number of syllables should be linked to a foot. Only if there is no place anymore in an existing foot and as a result syllables remain unlinked, is a new foot created, to which as yet unlinked syllables can be linked.

terface *contains* information equivalent to the statement “CVC syllables count as light.” Therefore, in such a theory, this information *is* available at the time of the working of CL. In Hayes’ theory, by contrast, the need to resort to an awkward interpretation of ‘maximality’ is the result of the model chosen.

#### 4.8 CL through glide formation

The second type which in the true constituent type cannot be explained through a reshuffle of association lines concerns glide formation. Hayes (1989:280) reports that this type is widespread among Bantu languages (Odden 1981, Clements 1986), Japanese (Poser 1986), Old Icelandic (Hock 1986), and Old English (Wright & Wright 1925). The following form exemplifies this type of CL:

(38)  $tia \Rightarrow tja:$

In other versions of this type of CL, segments in the nucleus of the previous syllable can be lengthened:

(39) a.  $akia \Rightarrow ak:ja$       b.  $eria \Rightarrow e:rja$

The type exemplified in (39a) is found in Ilokano, the type in (39b) in Middle English (Hayes 1989:269–279). The reason why the constituent model can not provide us with an explanation of the lengthening in these three cases is, just like in the case of CL by vowel loss ( $talə \Rightarrow ta:l$ ), that the syllable of the vowel that has been deleted or turned into a glide has ceased to exist. Hence there are no empty subsyllabic nodes for other elements to spread to. We have seen in the case of CL through vowel loss, however, that there was another, foot based reason for CL to take place. Therefore, we could hypothesise that here too, a podic factor can be involved.

To test this, we should look into the foot structure of the languages concerned. Unfortunately, we have no information at our disposal about the foot structure of the languages where the lengthening types in (38) and (39a) are found. Information is available on the foot structure of Middle English (39b). Recall from section 3.5 that Minkova posits the foot structure to be of the form SW(W). A form where the type of CL applies is given

in (40) (Hayes 1989:277).

(40) pasiəns  $\Rightarrow$  pa:sjəns 'patience'

Hayes (*ibid.*) quoting Jespersen (1909) points out that the glide formation ( $iV \Rightarrow jV$ ) was completed by the early Middle English period. The lengthening took place in roughly the same period. Hayes accounts for the CL in the following manner:

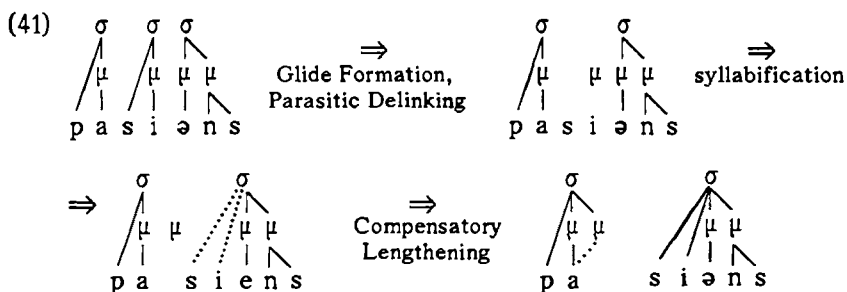

As we will now show, this analysis is ill-motivated, because the original form as given by Hayes is incorrect. For this, one has to consider the underlying form for 'patience'. As one can read in any manual on Old French or in any description of the historical development of the French sound system (e.g., Fouché 1958:524, Raynaud de Lage 1970:12, Pope 1956:118), the schwa in word final position was pronounced in this language. When the form was imported from Anglo-Norman into English, this form still contained a final schwa in *all* dialects of Old-French, including Anglo-Norman. The drop of the final schwa occurred much later in the history of French than the period of the borrowing of this word from Anglo-Norman into Middle English. The process of final schwa drop started only in the 14th century and was completed in the 18th century (Guiraud 1972:75),<sup>13</sup> well after the adoption of the word in Early Middle English, and the working of CL. In reality the initial form was as in (42):

<sup>13</sup> According to Fouché (1958:524) schwa-drop in word-final in postconsonantal position began to develop only in the middle or towards the end of the 15th century. Pope (1956:118) mentions that in the educated speech of Paris schwa was retained in this position into the later 16th century.

(42)  $pat^{s}ient^{s}\bar{a}$ 

The date of the earliest noted occurrence of the word is listed by lexicologists as 1120, when it was written *paciencie* (Robert 1973:1250). It occurs in this form also in Anglo-Norman (Rothwell 1988:485). Contemporary sources indicate that the French spoken in England became progressively pronounced with Middle English accentuation (Olga Fischer, personal communication). Therefore, we may assume that Middle English metrical structure was imposed on words like  $pat^{s}ient^{s}\bar{a}$ . We have seen in section 3.5 that the foot structure in early Middle English, as postulated by Minkova (1985), is S W (W). This gives us the following foot structure for  $pat^{s}ient^{s}\bar{a}$ . For reasons of transparency, we use the same version of the constituent model as Minkova in (1985:172) (cf. (21), above), although the model can easily be converted in our particular version of the constituent model. The onset nodes, irrelevant for syllable weight, have been omitted. A heavy rhyme in Minkova's model is dominated by two podic branches.

## (43)

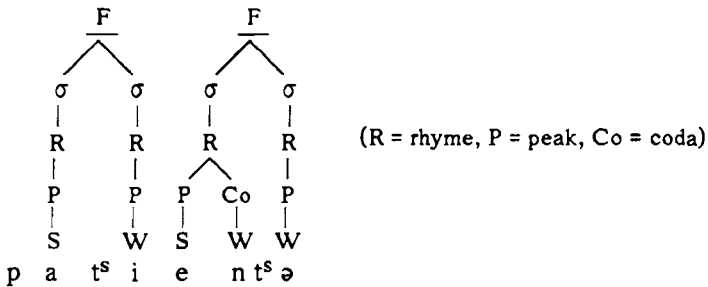

This is the only way in which this form can be parsed into permissible Middle English feet, because, as discussed in the previous section, a heavy syllable cannot belong to two different feet. The affricate  $t^s$  reduced to  $s$  in the course of the 13th century. The form then became [pasiens̄]. Because of the full spirantisation  $t^s \Rightarrow s$ , the high vowel  $i$  could become a glide:  $*t^s j$  was not a permissible onset, but  $s j$  was. This means that after the gliding of the  $i$ , the metrical structure of the form was as follows:

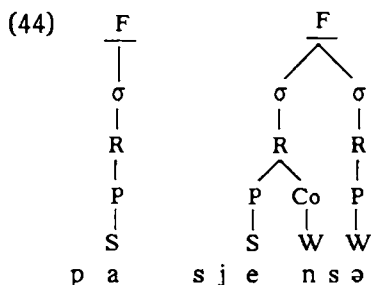

Note that the first syllable of (44) is illicit, because it contains only one branch, while it should contain minimally two. In principle, there are two options to resolve this situation. The first one is to incorporate the material of the illicit foot into another foot. This solution is viable if a foot is available. However, in (44), the second foot is maximally filled already: it contains three branches. Therefore, the only way out, the second option must be chosen, the enlargement of the first foot. This operation is already familiar to us, because it is exactly the same as the one which has taken place in the cases of CL through vowel loss (*talə* ⇒ *ta:l*), see section 3.5. The only option to make the foot structure of (44) well-balanced is to lengthen the syllable which constitutes the first foot.

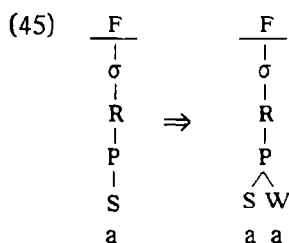

This long *a* is exactly what we get: *pasiəns* ⇒ *pa:sjəns*. The drop of the final schwa has taken place later. This is confirmed by the fact that words like 'patience' were used mostly in the South, where the Anglo-Norman and Parisian influence was greatest, while as indicated by Minkova (1982:43) and others, word final schwa loss started in the North and reached the South only later.

The analysis of CL through glide formation presented here has, as Minkova's analysis of CL through vowel loss, the advantage mentioned in sec-

tion 3.5, that one does not have to assume that there are elements, in this case moras, that are not subject to parasitic delinking.

#### 4.9 Excluding nonexistent CL types

We now come to the two hypothetical types of CL which are excluded in Hayes' model, and which he says are not excluded in 'X'-theory. We will see that our theory too, excludes this type of CL.

The two nonoccurring types of CL ("asymmetries") excluded in Hayes' moraic theory concern (i) onset deletion and (ii) vowel deletion in an initial syllable. Let us first consider onset deletion. If an onset is deleted, this does not result in the lengthening of a specific element. This is exhibited in the following hypothetical, but nonoccurring cases (Hayes 1989:281):

- (46) a. \*sa ⇒ \*a      b. \*osa ⇒ \*oa:      c. \*osa ⇒ \*o:a  
 d. \*sla ⇒ \*sa:      e. \*sta ⇒ \*ta:

This type of CL is excluded in Hayes' theory because, as we have seen, onset consonants are not dominated by moras, so there is nothing to spread to. Under X-theory (the term is used for all theories where CL is explained by processes on the level of the CV-tier), the process can easily be derived (we are taking here (46a,b,c) as examples, copied from Hayes 1989:284):

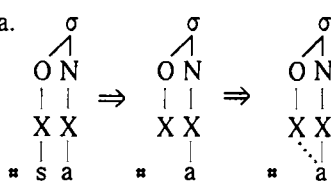
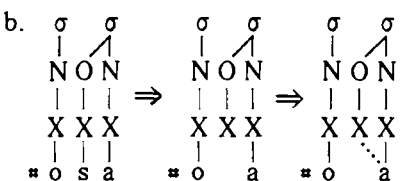
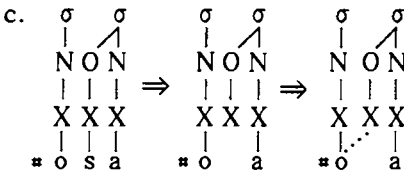
- (47) a. 
- b. 
- c. 

The other asymmetry, CL in the case of vowel loss in an initial syllable, if it occurred, would take place as follows (Hayes 1989:284):

(48) \* əla ⇒ \* la:

As Hayes points out, X-theory could easily derive this result, in a way which resembles the “double flop”, cf. (49) (Hayes 1989:286).

(49)

= [la:]

Under the moraic model, this type of CL is claimed to be excluded.<sup>14</sup> This theory “derives vowel loss cases using Parasitic Delinking. For Middle English, this disassociates the /l/ of /talə/ from its mora, thus rendering the mora accessible for the spreading of /a/ ...” (Hayes (1989:286), referring to the case in (11), (12) (*talə* ⇒ *ta:l*)). If a vowel on the left is deleted, Parasitic Delinking is not applicable. The *l* remains linked to the second syllable, and association of the vowel to the empty mora is impossible due to the prohibition against crossing association lines:

(50)

\*

The fact that the two non-occurring CL types are excluded by the moraic model seems to provide important additional evidence for this model. However, the constituent model of the syllable *also* predicts that this type of CL cannot occur, at least not by spreading within to a syllabic constituent. Let us first consider the onset deletion case. Here the explanation is as straightforward as under the moraic model. The spreading of the vowel to

<sup>14</sup> Contrary to Hayes' claim, the CL type displayed in (48) is not fully excluded under the moraic theory. The following CL is conceivable, *ija* ⇒ *ja:* (Norval Smith, personal communication):

the emptied onset in cases like (46a,b,c) ( $sa \Rightarrow a$ ;  $osa \Rightarrow oa$ ;  $osa \Rightarrow o:a$ ) does not take place, simply because the onset is not accessible (or sub-categorised) for vowels (except the elements that can be syllabic as well as nonsyllabic, frequently, for example, high vowels and sometimes liquids and nasals).

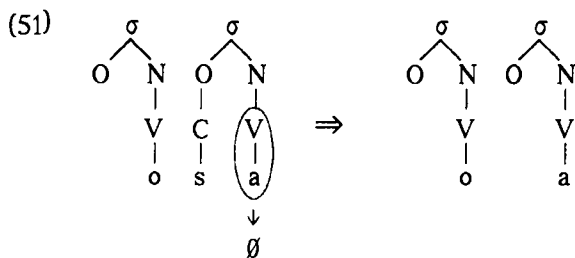

In cases like (46d,e) ( $sla \Rightarrow sa$ ;  $sta \Rightarrow sa$ ), the spreading does not happen for an additional reason: the onset in these cases is still filled by an element, the *s*.

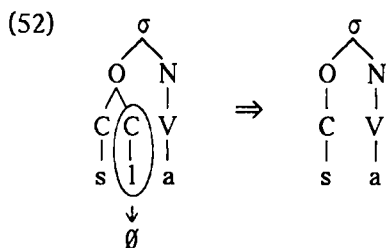

In contrast to the moraic model, in the constituent model of the syllable linking takes place through the normal association conventions of autosegmental phonology. Recall from section 4.1 that it is through the workings of the autosegmental association conventions (mapping, dumping, spreading) that the links between the segments (or skeletal slots) and the subsyllabic nodes are established. These conventions were originally devised only for linking tones to tone bearing units (TBU's), but later they were also assumed to be applicable for linking between other levels. Now in (46d,e) the *s* and the *a* remain linked to, respectively, onset and nucleus (first and second nodes of a binodal syllable structure). Therefore, there will not be a one-to-one association, because both segments are already linked to a



segment bearing unit. In addition, neither spreading nor dumping will take place for the same reason (respectively: because there are no unlinked segment bearing units or unlinked segments). Hence, there will be no CL in this case.

The second non-occurring CL type, the case of vowel loss in an initial syllable (cf. (48)), is also ruled out in the true constituent model. To see this, let us consider the configuration that would arise after initial vowel loss in the true constituent model taking (48): ( $\emptyset la \Rightarrow la:$ ) as an example:

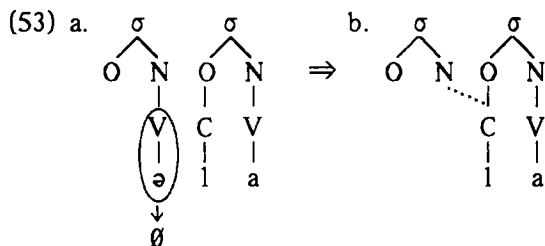

In (53a), the V dominating *a* cannot spread to an empty subsyllabic node, as this would involve crossing association lines. Hence, the outcome [la:] is impossible. The only thing that can happen is inverse CL, as already described in section 4.4. As displayed in (53b), the C dominating *l* can spread to the nucleus position of the first syllable, provided the language in question can have syllabic liquids. The outcome would be [l̩la]. This is fully parallel to the *pila* ⇒ *p̩lla* case, given above in (37d), (38).

## 5. Conclusion

In this article it was our aim to show the inadequacy of a syllable model in which the mora is a *constituent part*. Our second objective was to show that the *true constituent model*, as proposed in Noske (1989,1992) does not suffer from the flaws of the moraic model.

First, it was argued that the lack of an adequate account for the behaviour of glides, which was mentioned in the literature as a severe drawback of Hyman's (1985) model, remains a problem in a moraic model where consonants are intrinsically non-moraic, as in Hayes' model. In such a model, one cannot account for the free variation between high vowels and glides

which is often found in languages. In a model such as Hyman's where glides are moraic, one cannot account for the fact that sometimes high vowels and glides do not always alternate with each other. In a true constituent model, such as ours, the problem does not exist, since subsyllabic nodes are labeled and segments are categorised, partially on a language specific basis, for the node or nodes to which they can be linked.

Then, taking Hayes' (1989) model as representative of the moraic model of the syllable, we have shown that major problems arise because of the hybrid character, partly autosegmental, partly metrical, of the type of representation which a moraic syllable model entails. There is practically no constraint in the possibilities of association. In this, the moraic model contrasts with the true constituent model which, for its part, is fully autosegmental in nature and is subject to the well-defined constraints of autosegmental phonology.

Third, Hayes has to posit, idiosyncratically, that moras are not subject to Parasitic Delinking, a principle which he himself invokes for the deletion of other nodes.

Fourth, we have shown that the crucial types of compensatory lengthening which Hayes adduces as motivation for a moraic model, may also be described by a true constituent model, where spreading takes place to the subsyllabic constituents.

Fifth, the two types of CL which cannot be accounted for by the spreading of a segment to a subsyllabic constituent in the true constituent model, i.e., CL through vowel loss and CL through glide formation, were shown to be represented in an empirically inadequate way in Hayes (1989). As Minikova (1985) has shown for CL true vowel loss, and as we have shown above for CL through glide formation, these CL types are the result of a minimal foot quantity requirement.

Sixth, the nonexisting CL types excluded in the moraic syllable model proposed by Hayes are also excluded in the true constituent model.

We can conclude that the moraic model of the syllable proves unsatisfactory and that the true constituent model is the best alternative.

## Bibliography

- Archangeli, Diana, 1989. Prosodic Syllabification and Yawelmani 'CVVC' Syllables. Manuscript, University of Arizona, Tucson.
- Archangeli, Diana 1991. Syllabification and prosodic templates in Yawelmani. *Natural Language and Linguistic Theory* 9, 231-283.
- Bartoněk, Antonín, 1966. *Development of the long-vowel system in Ancient Greek dialects*. Praha: Státní Pedagogické Nakladatelství.
- Bubeník, Vít, 1983. *The phonological interpretation of Ancient Greek*. Toronto: University of Toronto Press.
- Buck, Carl Darling, 1955. *The Greek dialects*. Chicago: University of Chicago Press.
- Clements, George N., 1982. Compensatory Lengthening: an independent mechanism of phonological change. Bloomington: Indiana University Linguistics Club.
- Clements, George N., 1986b. Compensatory lengthening in Luganda. In: Wetzels, Leo & Engin Sezer (eds.), *Studies in compensatory lengthening*. Dordrecht: Foris; 37-77.
- Collinge, Nigel E., 1985. *The laws of Indo-European*. Amsterdam & Philadelphia: Benjamins.
- Fouché, Pierre. 1958. *Phonétique historique du français. Volume II: Les voyelles*. Paris: Klincksieck.
- Giegerich, Heinz J., 1981. "Zero syllables in metrical phonology." In Dressler, Wolfgang U., Oskar E. Pfeiffer & John R. Rennison (eds.) *Phonologica 1980: Akten der 4. internationalen Phonologietagung*, 153-60.
- Giegerich, Heinz J., 1985. *Metrical phonology and metrical structure*. Cambridge: Cambridge University Press.
- Goldsmith, John, 1976. Autosegmental phonology. Ph.D. dissertation, M.I.T., Cambridge, Mass., Bloomington, Ind: I.U.L.C. (Published in 1979 by Garland, New York).
- Guiraud, Pierre, 1973. *Le moyen français*. Paris: Presses Universitaires de France.
- Hayes, Bruce, 1981. *A metrical theory of stress rules*. Bloomington: Indiana University Linguistics Club.
- Hayes, Bruce, 1982. Extrametricality and English stress. *Linguistic Inquiry* 13; 227-276.
- Hayes, Bruce, 1987. A revised parametric metrical theory. *NELS* 17, vol. 1; 274-289.
- Hayes, Bruce, 1989. Compensatory lengthening in moraic phonology. *Linguistic Inquiry* 20; 253-306.

- Hock, Hans H., 1986. Compensatory lengthening: in defence of the concept of 'mora'. *Folia Linguistica* 20; 431-460.
- Hulst, Harry van der & Norval S.H. Smith, 1985. The framework of autosegmental phonology. In: Hulst, Harry van der & Norval S.H. Smith (eds.), *Advances in nonlinear phonology*. Dordrecht: Foris; 3-55.
- Hyman, Larry M., 1984. On the weightlessness of syllable onsets. In C. Brugman & M. Macaulay (eds.), *Proceedings of the tenth annual meeting of the Berkeley Linguistics Society*.
- Hyman, Larry M., 1985. *A theory of phonological weight*. Dordrecht: Foris.
- Itô, Junko, 1986. Syllable structure in prosodic phonology. Ph.D. dissertation, University of Massachusetts, Amherst.
- Itô, Junko, 1989. A prosodic theory of epenthesis. *Natural Language and Linguistic Theory* 7; 217-259.
- Jackendoff, Ray S., 1977.  *$\bar{X}$ -syntax: A study of phrase structure*. Cambridge, Mass.: MIT Press.
- Jespersen, Otto, 1909. *A modern English grammar on historical principles, Part I: Sounds and spellings*. London: George Allen & Unwin.
- Kaye, Jonathan D. & Jean Lowenstamm, 1984. De la syllabicité. In: Dell, François, Daniel Hirst & Jean-Roger Vergnaud (éds.), *Forme sonore du langage*, Paris: Hermann, 123-159.
- Lejeune, Michel 1972. *Phonétique historique du mycéen et du grec ancien*. Paris: Klincksieck.
- Liberman, Mark & Alan Prince, 1977. On stress and linguistic rhythm. *Linguistic Inquiry* 8; 249-336.
- McCarthy, John J. & Alan S. Prince, 1986. Prosodic morphology. Manuscript, University of Massachusetts & Brandeis University.
- Meister, Richard, 1882. *Die Griechische Dialekte. 1. Band: Asiatisch-Äolisch, Bötisch, Thessalisch*. Göttingen: Vandenhoeck & Ruprecht.
- Minkova, Donka, 1982. The environment of open syllable lengthening in English. *Folia Linguistica Historica* 3; 29-58.
- Minkova, Donka, 1985. Of rhyme and reason: some foot-governed quantity changes in English. In: Eaton, Roger, Olga Fischer, Willem Koopman & Frederike van der Leek (eds.), *Papers from the 4th international conference on English historical linguistics*. Amsterdam: John Benjamins; 163-178.
- Nakatani, L.H. & J.A. Schaffer, 1978. Hearing 'words' without words: prosodic cues for word perception. *Journal of the Acoustical Society of America* 63; 234-45.
- Noske, Roland G., 1989. Syllable geometry. *Belgian Journal of Linguistics* 4; 119-144.
- Noske, Roland G., 1992. A theory of syllabification and segmental alternation.

With studies on the phonology of French, German, Tonkawa and Yawelmani. Ph.D. dissertation, Katholieke Universiteit Brabant, Tilburg.

- O'Connor, Joseph D., 1973. *Phonetics*. Harmondsworth: Pinguin.
- Odden, David, 1981. A nonlinear approach to vowel length in Kimatuumbi. Manuscript, Ohio State University, Columbus.
- Odden, David 1986. Review of Hyman (1985). *Language* 62, 669-673.
- Prince, Alan S. 1985, "Improving the tree". *Proceedings of the Berkeley Linguistic Society* 11, 511-562.
- Poser, William 1986. Japanese evidence bearing on the compensatory lengthening controversy. In: Wetzels, Leo & Engin Sezer (eds.), *Studies in Compensatory Lengthening*. Dordrecht: Foris, 167-186.
- Pope, Mildred 1956. *From Latin to Modern French*. Manchester: Manchester University Press.
- Raynaud de Lage, Guy, 1970. *Introduction à l'ancien français*. 7ième éd. Paris: Société d'Édition d'Enseignement Supérieur.
- Robert, Paul, 1973. *Dictionnaire alphabétique & analogique de la langue française*. Paris: Société du Nouveau Littré.
- Rothwell, William 1988. *Anglo-Norman Dictionary. Fascicle 5: P-Q*. Under the general editorship of Louise W. Stone and William Rothwell. Fasc. 5 edited by William Rothwell with the assistance of Dafydd Evans. London: The Modern Humanities Research Association.
- Sheets, George A., 1974. *Problems in Greek dialectology: a reinterpretation based on a structural theory*. Ph.D. dissertation, Duke University. Ann Harbor: University Microfilms International.
- Steriade, Donca, 1982. Greek prosodies and the nature of syllabification. Ph.D. dissertation, M.I.T., Cambridge, Mass.
- Streitberg, Wilhelm, 1893. Ein Ablautproblem der Ursprache. *Transactions (and Proceedings) of the American Philological Association* 14; 29-49.
- Streitberg, Wilhelm, 1894. Die Entstehung der Dehnstufe. *Indogermanische Forschungen* 3; 305-416
- Wetzels, Leo, 1986. Phonological timing in Ancien Greek. In Wetzels, Leo & Engin Sezer (eds.) *Studies in compensatory lengthening*. Dordrecht: Foris; 297-344.
- Wright Joseph & Elisabeth M. Wright, 1925. *Old English Grammar*. London: Oxford University Press.