

# Syllabification and Syllable Changing Processes in Yawelmani\*

Roland Noske

*University of Amsterdam/ZWO*

## 0. INTRODUCTION.

It has been observed by Kisseberth (1970:293) that in Yawelmani, 'there are a number of processes, which, it might be said, "conspire" to yield phonetic representations which contain no word final clusters and no trilliteral clusters.'

The processes mentioned by Kisseberth are:<sup>1</sup>

$$(1) \quad \emptyset \rightarrow i / C \_ C \begin{cases} \# \\ C \end{cases}$$

$$(2) \quad C \rightarrow \emptyset / CC+ \_$$

Rule (2) is ordered before (1) and applies only in forms containing a suffix which selects the 'zero' stem of the verb bases (in Newman's (1944) (the main source on Yawelmani) terminology) (I will discuss this selection process later in detail).

Looking back at this today we can see that these rules work to avoid impermissible syllables in Yawelmani. If we look into the corpus provided by Newman (1944), we see that with very few exceptions, the possible syllable types are restricted to CV, CVC and CV<sub>i</sub>V<sub>i</sub> (or CV:). Once we have established these three types, it can be seen that there are even more rules taking part in the conspiracy to restrict syllables to these three types than the ones mentioned by Kisseberth. Consider the following two rules proposed by Kuroda (1967) and Kisseberth (1969)<sup>2</sup>:

$$(3) \quad \text{Shortening} \\ V \rightarrow [-\text{long}] / \_ C \begin{cases} \# \\ C \end{cases}$$

$$(4) \quad \text{Elision} \\ V \rightarrow \emptyset / \_ V$$

\* This paper differs in important respects from the one presented during the non-linear phonology workshop in August 1983. I would like to thank Norval Smith, Irene Vogel, Diana Archangeli, Stanley Newman† and Harry van der Hulst for their comments. This work was supported by the *Stichting Taalwetenschap*, which is funded by the Netherlands Organisation for Pure Scientific Research (ZWO).

Examples of these processes are given in (5) and (6):

(5) /laga:+t/ [lagat] 'spend the night' (passive aorist)

(6) /laga:+in+hin/ [lagihin] (mediopassive+aorist)

Because the syllable was not recognised as a relevant phonological unit when Kisseberth wrote his article, he was not aware of the complete extent of the conspiracy.

Kisseberth asks linguists to look at the relationship he felt between the rules. Since the publication of his article, conspiracies have been noted in a great many languages, but no attempt has been made, to my knowledge, to express the relationship formally.

I will here express the relationship in a formal way, by making use of the concepts of syllabification and the CV-tier. But first of all, I will treat a proposal made by Archangeli (1983a,b).

#### 1. ARCHANGELI'S PROPOSAL.

In Yawelmani, the regular verb, which Newman refers to as the *basic verb*, includes two or three consonants. There are three possible consonant-vowel configurations, which are given in (7).

(7)      *A1*                  *A2*                  *B*  
            CVC(C)          CVVC(C)          CVCVV(C)

*A1*, *A2* and *B* correspond to Newman's classification.<sup>3</sup> When combined with the majority of affixes, verbal stems take one of the forms listed above. Examples are given in (8).

(8)	<i>stem selected</i> <i>by the base</i>	<i>aorist</i> (-hin) <sup>4</sup>	<i>passive aorist</i> (-t)	<i>gloss</i>
	<i>IA1</i> dub	dubhun	dubut	'lead by hand'
	<i>IA2</i> hiix	hexhin	heexit	'be fat'
	<i>IB</i> lagaa	lagaahin	lagat	'spend the night'
	<i>IIA1</i> lukl	lukulhun	luklut	'bury'
	<i>IIA2</i> wuu'y	woo'yuhun	wo'yut	'sleep'
	<i>IIB</i> biniit	binethin	bineetit	'ask'

In these forms the working of several phonological processes in Yawelmani can be seen. A harmony process has taken place in the forms of *IA1*, *IIA1* and *IIA2*. This process works directionally from left to right and

rounds unrounded vowels if preceded by rounded vowels with the same specification for the feature [high]. This accounts for the *u* in *dubhun*. The process has been formulated by Archangeli as:<sup>5</sup>

- (9) Vowel Harmony (VH)
- $$\begin{array}{c} [+round] \\ \swarrow \quad \searrow \\ V \quad \quad V \\ [\alpha high] \quad [\alpha high] \end{array}$$

Also, we can see the working of the Epenthesis process formulated by Kuroda and Kisseberth as in (1), in the passive aorist forms of the verbs given under *IA1*, *IA2*, *IIA1*, *IIA2* and *IIB*. In the cases of *IA1*, *IIA1*, and *IIA2*, the inserted *i*'s have turned into *u* by the working of VH. An *i* has also epenthesised in the aorist form of *IIA2*, and has also subsequently been turned into *u* by VH.

Another process to be noted is Lowering, given as formulated by Archangeli (1983a:361) in (10), which lowers long high vowels.

- (10) Long Vowel Lowering (LVL)
- $$\begin{array}{c} VV \rightarrow VV \\ \quad \quad \quad \downarrow \\ \quad \quad \quad [-high] \end{array}$$

The working of this process can be seen in the aorist and passive aorist forms of the verbs given as examples of types *IA2* and *IIA2*. In the aorist form of the verb given as example of type *IA2*, the underlying *ii* has been changed to *ee* by LVL. In the aorist form *ee* has subsequently been turned to *e* due to the Shortening process given in (3). In the verb given as example of type *IIA2*, the long *uu* has given rise to the harmony process, rounding the high vowels in the following syllables, has then been lowered to *oo*, and is then shortened to *o* in the passive aorist case.

There are, however, a number of affixes which select a different consonant-vowel configuration for the verb stem that the one which, so to speak, 'belongs' to the verb in question. Examples are given in (11).

- |      |                                      |                                 |  |
|------|--------------------------------------|---------------------------------|--|
| (11) | <i>stem selected<br/>by the base</i> | <i>desiderative-<br/>aorist</i> | <i>reflexive/reciprocal<br/>adjunctive</i> |
|      |                                      | -(h) atn+ hin                   | -wsiil                                     |
|      |                                      | <i>selects: CVC(C)</i>          | <i>selects: CVCVV(C)</i>                   |
|      | <i>IA1</i> dub                       | dubhatinhin                     | dubowsol                                   |
|      | <i>IA2</i> hiix                      | hixhatinhin                     | hixewsel                                   |

<i>IB</i>	lagaa	laghatinhin	lagawsel
<i>IIA1</i>	lukl	luklathin	lukoowsel
<i>IIA2</i>	wuuʔy	wuʔyathin	wuʔooysel
<i>IIB</i>	biniit	bintathin	bineetiysel

Archangeli gives the following account of the alternations of the verb stems in Yawelmani. She posits the three rules given in (12):

- (12) a. insert CVCC  
 b. insert CVVCC  
 c. insert CVCVVC

The affixes which select a verb stem type of their own carry a diacritic which triggers one of the rules in (12). The other affixes, like the aorist in (8) do not carry such a diacritic. Furthermore, according to Archangeli, the verbs themselves carry a diacritic triggering one of the rules in (12). This diacritic comes into action only if there is no affix with its own diacritic, otherwise the diacritic of the affix takes precedence by means of a new version of the Elsewhere Condition. One can thus speak of a 'default template' supplied by the verb.

Consider now the aorist forms in (11). The *h* is sometimes present, namely in the cases of the biconsonantal verb roots (the *IA1*, *IA2* and *IB* cases), but the segment is absent in the cases involving a triconsonantal verb root (the *IIA1*, *IIA2* and *IIB* cases). Archangeli accounts for this in the following manner: she assumes the representation as in (13).

- (13) (h) t n    consonantal melodic tier  
 V C C                  apply (12a)                      skeleton (CV-tier)  
 a    vocalic melodic tier

In (13), *h* is parenthesised to indicate that this element is extra-prosodic, i.e. 'it does not participate in the normal prosodic activity that elements are subject to, here association' (Archangeli (1983a:377)). When a verb melody is inserted the extramelodic *h* is no longer peripheral but is open for association with an element on the consonantal melodic tier of the affix. See (14a,b) which represent the *IA1* and *IIA1* desiderative aorist forms in (11).

- (14) a. d    b    h    t    n    h    n  
           |    |    /    |    |    |    |  
           C V C C + V C C C V C  
           |            |            |  
           u            a            i

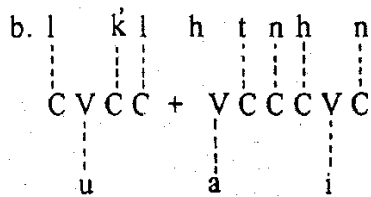

In (14b), *h* remains unassociated because there is no empty slot for it to be linked to.

Archangeli uses the alternations of the type displayed in *-(h)atn-* as one of three arguments for the assumption of an independent CV-tier in Yawelmani, on which the templates supplied by the affix are located. Although I share part of her general conclusion and think that the assumption of the skeleton can account for morphologically conditioned alternations in Yawelmani which hitherto could not really be explained, I will challenge here her argument that alternations such as the *h/∅* alternation in *-hatn-* provide motivation for the assumption of the skeleton.

First, it should be noted that the *h/∅* alternation (for which Kisseberth has formulated rule (2)) is analysed by Archangeli as being the result of purely an association process, while as we have seen it takes part in a conspiracy to avoid unpermissible syllable structure. The relationship with syllable structure of other processes taking part in the conspiracy, e.g., Shortening, is recognised by Archangeli (1983a:361).<sup>6</sup>

Second, it should be noted that the analysis given by Archangeli is counter to an essential feature of the theory of lexical phonology developed by Mohanan (1982), Kiparsky (1982, 1983), and Pulleyblank (1983), which she claims to assume (1983a:350). It is the assumption that the verb melody is inserted only after insertion of the affix, and that association has already taken place in the affix before it takes place in the verb stem. According to every proposal in lexical phonology, however, any affix cycle should follow a stem cycle. Therefore, there can be no such structure as the one posited by Archangeli in (13), where there is no verb melody and on which her analysis of the *h/∅* alternation in *-(h)atn-* crucially depends. Any association takes place from left to right, therefore the first morpheme to be associated is the root morpheme. Bearing this in mind, it can easily be shown that without Archangeli's assumption which goes against the essence of lexical phonology, her system will not work.

For this we have to consider two logical possibilities: the first is that insertion of the template by the statement *apply (12a)* in (13) takes place before association, the second is that it takes place after. In both situations we get the wrong result.

Looking at the first possibility, we get a form like in (15):

(15) l k l h t n h n

CVCC + VCCCC

u a

In (15), *h* is no longer peripheral and is therefore open for association. Association will produce (16), which is wrong.

(16) l k l h t n h n

CVCC + VCCCC

u a

(16) will eventually create, after epenthesis, the phonetic form \*[luklahitnih] and the final *n* remains floating. The result would thus be an absent/present alternation of the final segment of the affix, rather than of the first. If we assume, on the other hand, that association takes place before application of (12a), we get the the result in (17), creating the absurd outcome \*[ulukluh].

(17) l k l h t n h n

VCCCC

u a

The only way in which Archangeli's analysis could be saved, while maintaining the essence of lexical phonology, would be to assume that the non-alternating segments of the affix are underlyingly linked, i.e. linked in the skeleton, which would render her account extremely inelegant, since it cannot be assumed that the nonalternating segments of the stem are also underlyingly linked to the skeleton, as this skeleton is inserted by rule. Therefore, the key to the explanation of the *h/∅* alternation in *-hatn-* cannot be the alleged extraprosodicity of the alternating segment.

This becomes even more clear in my third objection against Archangeli's proposal, which is that there are other affixes in which there is also a seemingly morphologically conditioned alternation process between the presence and the absence of a segment which cannot be accounted for in the same way as Archangeli accounts for the *-hatn-/-atn-* alternation, because the segments in question are not morpheme-initial. These affixes

are: the consequent-gerundial  $-m(i)$ , precative  $-x(a)$ , imperative  $-k(a)$ , and consequent adjunctive  $-?h)iy-$ . The affix  $-?h)iy-$  does not appear in this form in Yawelmani, but in three other dialects of Yokuts, viz. Wikchamni, Gashowu and Choynimni (Newman, p. 163). It shows exactly the same behaviour as  $-(h)atn-$ , in that the  $h$  disappears if it finds two consonants right in front of it. The affix selects the 'strong' stem, as Newman terms it (which in Archangeli's system amounts to a CVCVVC template) and surfaces as  $-?hiy-$  when combined with a triconsonantal verb root but as  $-?iy-$  when combined with a triconsonantal one. Examples (from Gashowu) are given in (18)<sup>7</sup> (Newman, p. 163-4).

- (18) a. češe[-]-?hiy-a nim ?oʃsu? '(he) stole my knife', -a *objective*,  
 <\*čiši 'cut with the knife' (the root form postulated by Newman)
- b. hoyčus na kána[-]w-?iy-a 'I want a bed', -a *objective*,  
 <\*kanaw 'fall asleep'.

The sign [-] is used by Newman to indicate that the vowel has been shortened. It appears that this process is very similar if not identical to the  $-hatn-/-atn-$  alternation. But it cannot be resolved by the same means as Archangeli uses in that case. First and foremost of course, because  $h$  cannot be extraprosodic, since it is not peripheral. But even if we get rid of the need for employing the concept of extraprosodicity in the analysis by assuming the extremely inelegant solution of the nonalternating melodic elements of the affix being underlyingly linked, which works in the  $-(h)atn-$  case, even then we will not be able to account for the alternation in  $-?h)iy-$ . For this, consider the underlying form in (19), in which the alternating  $h$  is not linked to the skeleton, but the other, non-alternating, elements are:

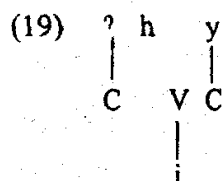

For (18a) the underlying form would then be:

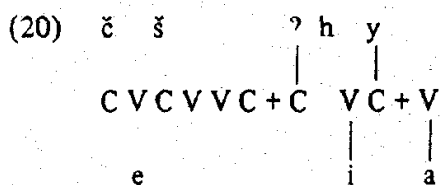

Association and spreading would produce:

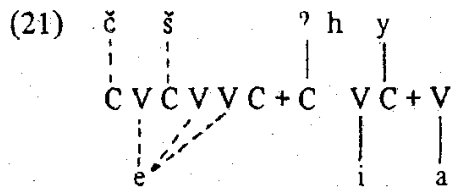

This would produce the incorrect phonetic form \*[češeeʔiya]. The correct form would only be produced if it was assumed that the link between the glottal stop and the C slot is broken and the glottal stop was linked to the rightmost C of the CVCVVC template. Then the *h* would be associated to the leftmost C slot of the skeleton of the affix:

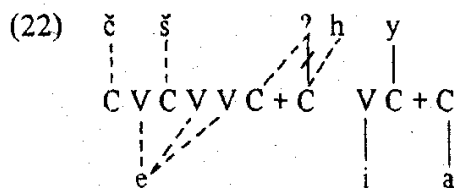

The process of dissociating the glottal stop and the leftmost C slot of the affix would, however, have to be formulated by means of a rule that would appear otherwise totally ad hoc.

For the alternations in the affixes  $-m(i)$ ,  $-x(a)$  and  $-k'(a)$ , Kisseberth (1969:28) has formulated the rule of Vowel Drop given in (23):

$$(23) \quad V \rightarrow \emptyset / V + C \_ \#$$

This rule is inadequate because certain nominal affixes of the shape  $+CV\#$  do not display vowel deletion when preceded by a vowel. An example is the indirect objective suffix  $-ni$ . The alternations  $-mi/-m$ ,  $-xa/-x$ ,  $-ka/-k'$  also occur in the very closely related dialect of Chukchansi. The conditioning of the alternations in this dialect is exactly the same as in Yawelmani and given the close relationship of the dialects we would like to account for them in the same manner. However, another suffix of the shape  $+CV\#$  exists in Chukchansi in which the vowel is *not* deleted if the suffix is immediately preceded by a vowel, viz. narrative aorist  $-ta$  (Newman, p. 125). This makes us think that a purely segmental account like the one by Kisseberth cannot be maintained.<sup>8</sup>

This becomes even more clear if we take into consideration the effect of the alternations of the affixes  $-m(i)$ ,  $-x(a)$ ,  $-k'(a)$ . Consider the forms given in (24) and (25) (from Newman, p. 29):



(24) kás-ka 'pierce it'

(25) taxa[·]-k 'bring (it)'

We see here that if the final *a* in (24) were to be omitted, a forbidden syllable structure CVCC would ensue (into which eventually an *i* would be epenthesised). In other words, the vowel is present only if necessary in order to produce a correct syllable structure. This process appears to be syllabically conditioned and also to be part of the conspiracy (although in a different way, in that it is the *realisation* rather than the *deletion* of the vowel that enters into the conspiracy). This type of alternation cannot be accounted for in Archangeli's system, because that system crucially depends on the existence of triconsonantal templates for biconsonantal verbs. Thus only alternations involving affix-initial consonants can be accounted for, not alternations involving vowels.

In my analysis, to be presented below, the above mentioned alternations are accounted for as following from syllabic structure, and not from the presence of unlinked nodes in the skeleton of the verb stem. I will therefore assume that these unlinked nodes do not exist and propose a somewhat different account of the morphologically conditioned alternations in the Yawelmani verb stem.

## 2. EXCURSUS ON YAWELMANI VERB MORPHOLOGY AND MORPHOLOGICAL THEORY.

As mentioned in section 1, the Yawelmani verb can take one of the forms: *CVC(C)*, *CVV(C)*, *CVCVV(C)*. As we have seen it is only the number of V's in the skeleton that can change under the influence of the 'template selecting' affixes. Either one, two, or three V's are present, but there is no alternation in the distribution of these V's in the skeleton. That is, there are no verb stems of, e.g., the shapes *CCV(C)*, *CVCV(C)*, *CVVCV(C)*. Once the number of V's in the skeleton is known, the shape of the skeleton is known also. In this respect, despite observations of a 'formal similarity between Semitic and Yokuts: the morphologically conditioned alternations in vowel and consonant patterning in roots' (Archangeli (1983a:348-9)), there is an important difference between this type of alternation and the type we find in Arabic which has been accounted for by McCarthy (1979). In Arabic we find alternations as in (26) (from McCarthy (1982:134)).

(26)	<i>binyan</i>	<i>Perfective Active</i>	<i>template</i>
	II	kattab	CVCCVC
	IX	ktabab	CCVCVC

In (26) the *location* of the vowels is also subject to alternation. In Yawelmani we only need information about the *number* of V's, while the remaining part of the information needed to determine the exact shape of the skeleton is provided by Morpheme Structure Conditions (or, in Kiparsky's (1983) framework, by lexical rules which in conjunction with the Strict Cycle Condition replace Morpheme Structure Rules (1983:11)).

Yawelmani differs from Arabic also in another important respect: the skeletal alternation plays only a secondary role in the differentiation between different morphemes, there is always an affix attached to a root and derived forms of one and the same root are never differentiated solely by their skeletal shapes, as in Arabic.

This brings us to a more general point. In languages like Dutch or English, as in a very large number of languages, we find no binyanim-like alternation. This means that if we assume association to take place in those languages, it must take place in a completely trivial way. This strange situation disappears if it is assumed that in these languages the elements on the melodic tiers are underlyingly linked. I will assume that this is indeed the case, and that the Semitic languages differ from, e.g., the Germanic languages in that the segments on the melodic tiers are *not* underlyingly linked to the skeleton.

For Yawelmani, in which as we have seen skeletal alternation plays a much less central role than in Arabic, I will assume that *only* the alternating segments are underlyingly linked.<sup>9</sup> This means that the underlying forms for the bi- and triconsonantal roots will be as in (27a) and (27b) respectively.<sup>10</sup>



In (27) the lower case c's and v's indicate arbitrary elements on the consonantal and vocalic melodic tiers respectively. The template insertion rules in (12) can now be replaced by rules inserting partial templates:

- (28) a. insert  $\emptyset$   
 b. insert V  
 c. insert VV

Lexical rules will now do the rest, creating the skeleton forms CVC(C), CVC(C) and CVCVV(C) respectively. Notice that stating rule (28a) is a distinct operation from stating no rule at all. To see this look at the

form *lagaa* in (8) and (11), the *-hatn-* morpheme, which in Archangeli's system selects the CVCC template carrying a diacritic triggering rule (12a), overrules the diacritic which the root carries by itself and which comes into action only if the affix does not carry a diacritic. The diacritic of the root in *lagaa* case selects (12c). I adopt this solution completely, only replacing (12) by (28).

As the existence of zero elements such as in (28a) has been defended extensively in the literature, I shall not do so here. After application of (28b) and (28c), spreading will link the unlinked  $\bar{V}$  or  $V$ 's to the relevant element on the vocalic melodic tier. For reasons that will become clear in section 4, I will assume that spreading applies only within the stem domain.

### 3. SYLLABIFICATION IN YAWELMANI.

I now come to my proposal for Yawelmani syllabification, which plays a crucial part in my formalisation of the relationship of the conspiring processes. I will assume the existence of the nodes Onset, Rhyme, Nucleus, Coda, dominated by the syllable. It should be pointed out that a syllable is always expanded in terms of these nodes, even if certain nodes are not filled with material at the level of the skeleton. The subsyllabic nodes are thus genuine nodes, not just labels on syllabic branches, as in many proposals concerning the syllable. As we will see in section 4, it is the possibility of subsyllabic nodes being empty, together with the tendency to avoid this emptiness, that conditions the syllable changing process in Yawelmani. These same two principles have been used in Noske (1982) to account for syllable changing processed in French.

Using the node Rhyme, I assume a hierarchically structured syllable, that is the type displayed in (29).

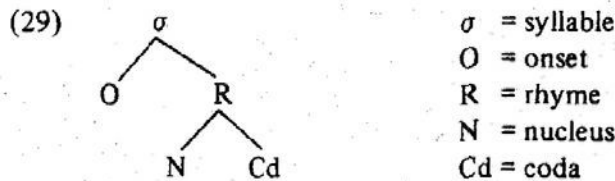

There is nothing in the present proposal, however, which prevents us from assuming a non-hierarchical (flat) structure as in (30).

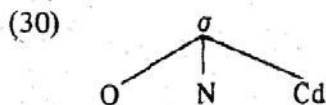

A flat structure is also proposed by Kahn (1976). Davis (1982) shows that a structure like (30) is preferable to (29). For our present purposes, however, the choice between (29) and (30) is not critical. For the ease of exposition I will therefore continue to use (29). I will assume the syllable structure conditions given in (31) and (32).

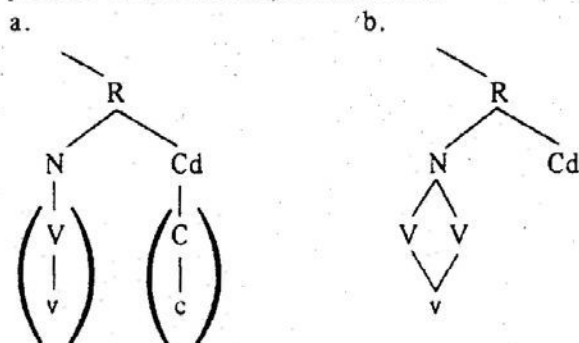
(31) *Yawelmani onset structure*(32) *possible Yawelmani rhyme structures*

Two remarks should be made here. First, the nucleus in (32a) may be empty. Like a number of proposals (e.g., ter Mors (1982) and Marlett & Stemberger (1983)), my analysis assumes that epenthesis will fill empty vocalic positions in the syllabic structure (in my proposal empty nuclei, in ter Mors' and Marlett & Stemberger's proposals empty V's). It is assumed that any empty nucleus left over will be filled by  $\bar{y}$ .

Secondly, the coda is obligatorily empty in (32b)! Given the complementary distribution of the long vowel  $\bar{v}$  and the filled coda, the reader will be tempted to propose the second V of a VV sequence to be dominated by the coda, thus replacing (32b) by (33).

## (33)

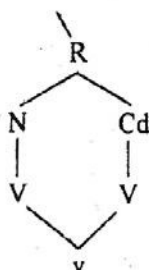

There are, however, a few objections against such a proposal. The phonetic basis of the concept of the coda, which is usually thought of as consisting of one or more postvocalic consonants, would be obliterated. Also, the prohibitions against diphthongs in Yawelmani would be expressed by a condition that would be of an extreme specificity (the V dominated by the coda should be linked to the same element on the vocalic melodic tier as the V dominated by the nucleus), while otherwise the coda would be very liberal as to the choice of elements it may contain: it does not matter whether the element is a C or V. If it were a C, there would be no restriction on the nature of the element on the consonantal tier which the C dominates. A further argument against (33) is that a CVVC syllable does occur in Yawelmani in some exceptional cases. With the assumption of the positive condition in (33) this is much more difficult to account for than with (32b), where only the requirement that the coda be empty need be dropped. Finally, the analysis of the syllable changing processes to be presented in section 4 would not work under the assumption of (33), while (32b) makes it possible to account for the syllable changing processes in a unified way.

In accordance with many proposals concerning (re)syllabification, I assume that syllabification is a persistent mechanism. It takes place according to the following principles:

- (34) Syllabification principles:  
 Syllable structures are mapped onto the skeleton  
 a. from right to left  
 b. in such a way that the number of empty nodes is minimised.

It is thus assumed that syllabic structures consisting of coda, nucleus, onset are projected onto the skeleton. The reasons for the directionality are threefold. The first reason is that if the mechanism were to apply in the other direction, i.e., from left to right, and encountered a postvocal  $\underset{c}{C}$ , it could not be determined to which syllabic node this element should be connected. For this, it would have to know whether the element following the  $\underset{c}{C}$  was a  $\underset{c}{C}$ , or a  $\underset{v}{V}$ . In the first case the  $\underset{c}{C}$  would be assigned to the coda (of the former syllable), in the second case to the onset (of the latter syllable). This means that the mechanism would have to look ahead. Application from right to left, however, yields no such problems, and the mechanism can be kept as simple as possible.<sup>11</sup> In that case, the mechanism will project an onset and link it with  $\underset{c}{C}$ , if the last projected node was a nucleus, and it will project a coda and link it with  $\underset{c}{C}$ , if the last projected node was an onset. Recall from (31) that an onset cannot be empty, hence the situation in (35) cannot occur.

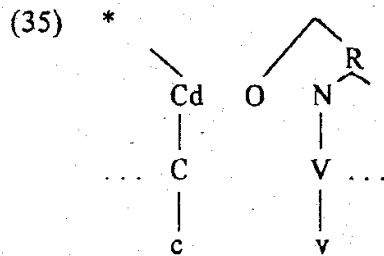

Here the onset would be empty. Therefore, a  $\overset{C}{\underset{V}{\sigma}}$  appearing to the left of a  $\underset{V}{\sigma}$  linked to a nucleus will always be linked to an onset.

The second reason why I assume syllabification to take place from right to left has to do with the epenthesis of *i*. As mentioned before, I assume that empty nuclei left over are eventually filled with  $\underset{V}{\sigma}$ . Consider the aorist form of the *IIA1* verb given in (8), repeated here as (36).

(36) lukulhun

The second *u* in this form is an epenthesised *i* that has been turned into *u* by VH. If it is indeed assumed that the *i* is inserted in an empty nucleus, syllabification from left to right would give the wrong result, viz. \*[luk'luhun] (or even \*[luk'luhnu] if it is assumed that the third *u* is also the result of epenthesis), because *k'* would be analysed as the coda of the first syllable and *l* as the onset of the second. Only then would the syllabification mechanism project an empty nucleus.

The third argument in favour of right-to-left application of syllabification are the shortening and elision processes which are formulated in a linear fashion in (3) and (4). With the assumption of the right-to-left directionality of syllabification these processes follow automatically from syllabification and need not be stated as independent processes. Consider the form in (37):

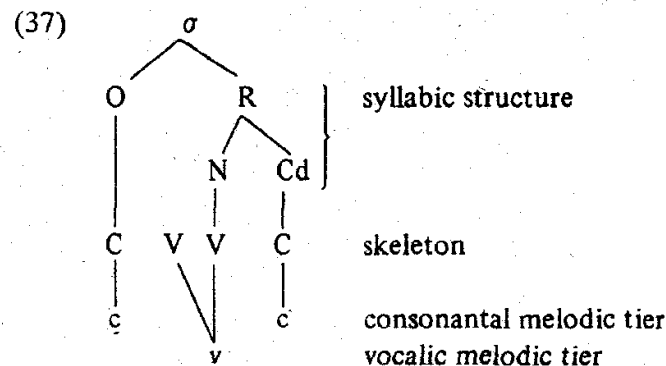

In (37), the leftmost *V* has not been syllabified, because the syllable

structure conditions in (31) and (32) do not permit two V's in the nucleus if the coda to its right is filled, and require the onset to its left to be filled with  $\bar{C}$ , so that the leftmost of the two adjacent V's cannot be connected to the syllabic structure. It is in this way that shortening falls out automatically, because an unsyllabified skeletal slot is not realised. Note that if syllabification were to apply from left to right, the mechanism would not 'know' at the moment of decision whether to link the two V's if the following coda was filled or not.

Turning now to the elision process, let us first consider elision in a closed syllable, which constitutes a case closely parallel to (37), cf. (38).

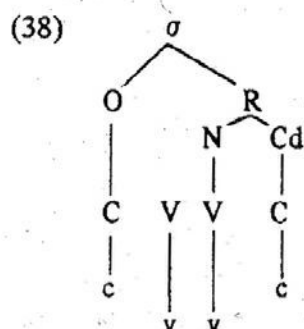

In (38), right-to-left syllabification links only the rightmost of the two contiguous V's to the syllabic structure, hence the leftmost V is phonetically not realised, which is the correct result. For an open syllable it is the requirement in (32b) that the two contiguous V's in one syllable be linked to a single element on the vocalic melodic tier that rules out the form in (39):

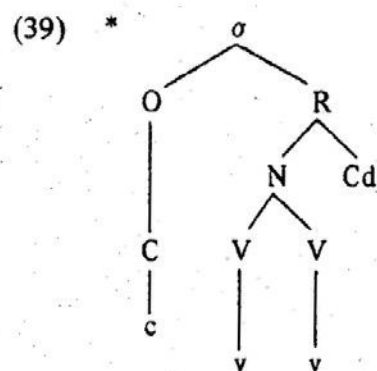

We thus see that we have already resolved two 'conspiring' processes by analysing them as a direct result of syllabification. The requirement in (34b) that the number of empty nodes be minimised is needed to prevent outcomes like (40) instead of (41):

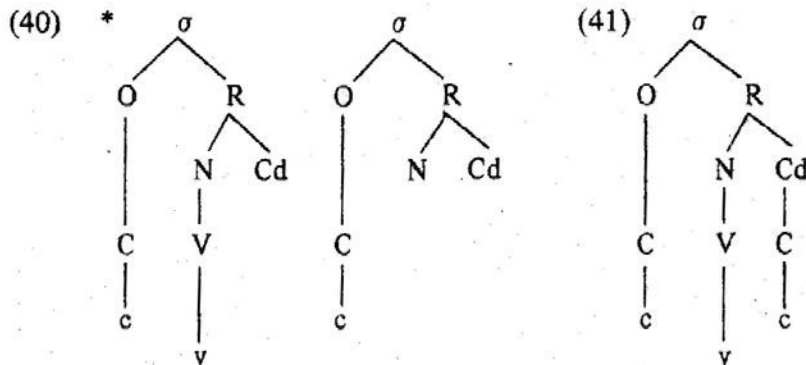

Because of the directionality in application, the requirement that the number of empty nodes be minimised means that a syllabic node O, N or Cd *has to* be linked to the skeleton if there is an appropriate slot available. We will see in section 4, that the Segmental Tier Association Rule (44) is conditioned by this same principle of minimisation of empty syllabic nodes.

#### 4. THE SEGMENTAL TIER ASSOCIATION RULE.

In this section, I will propose a rule that accounts for the *-hatn-/-atn-* alternation, as well as for the alternations: *-ka/-k*, *-mi/-m*, *-xa/-x* and *-?hiy-/-?iy-*.

I assume the form in (42) as the underlying form for *-hatn-*, instead of (43), which is the form which emerges in Archangeli's analysis after association and before the insertion of the root melody.

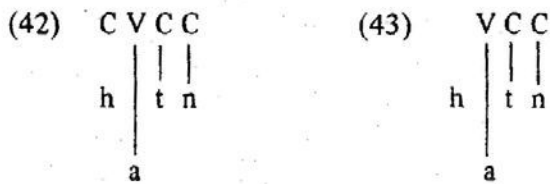

The difference between the underlying form proposed by me and the intermediate form in (43) in Archangeli's analysis is that (42) contains four skeletal slots, one of which is not linked to a melodic tier, while (43) contains only three, all of which are linked to a melodic tier. As we will see, the Segmental Tier Association Rule (STAR) will link the unlinked *h* to C under certain conditions. The reason why I have not preferred an underlying representation with only three skeletal slots, together with a rule which projects a skeletal slot for an element on a melodic tier, will be given below when I treat the alternation in the affixes *-k(a)*, *-m(i)*, *-x(a)*. We come now to STAR itself, which consists of two parts:



## (44) Segmental Tier Association Rule (STAR)

- a. associate an unlinked element on a melodic tier to an unlinked skeletal slot.
- b. condition: association may apply only if the resyllabified output contains less empty syllabic nodes than the input.

As mentioned in section 3, it is assumed that syllabification is automatic and persistent. By assuming STAR, we have replaced the automatic association by a conditioned rule. It is thus assumed that in languages where the elements on the melodic tiers are generally underlyingly linked (see section 2), the (exceptional) unlinked melodic elements are linked to the skeleton by rule. Note that condition (44b) reflects the same tendency as the syllabification principle in (34b), viz. the minimisation of the number of empty syllabic nodes. It is thus that the relationship of the alternation types  $-(h)atn-$ ,  $-?(h)iy-$  and  $-k(a)$  with syllabification and syllable structure in general will become clear.

I will now treat some cases which illustrate the working of STAR. The first case concerns the  $-(h)atn-$  type. Consider (45a,b) which are the underlying forms for *dubhatinhin* and *luklatinhin* (previously cited in (11) and (14)).

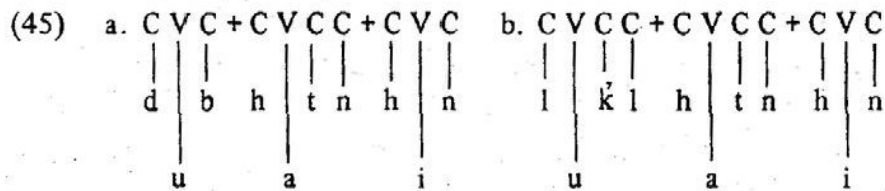

The  $-(h)atn-$  morpheme will now trigger morphological rule (28a) inserting the partial template  $\emptyset$ , hence overriding the root diacritics triggering other subrules in (28). This process, and initial syllabification will lead to the forms in (46):

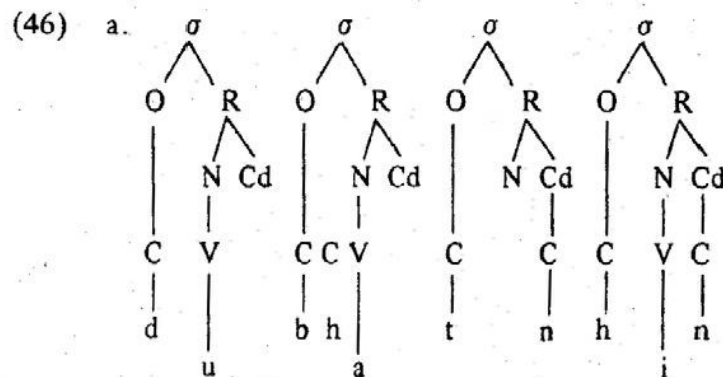

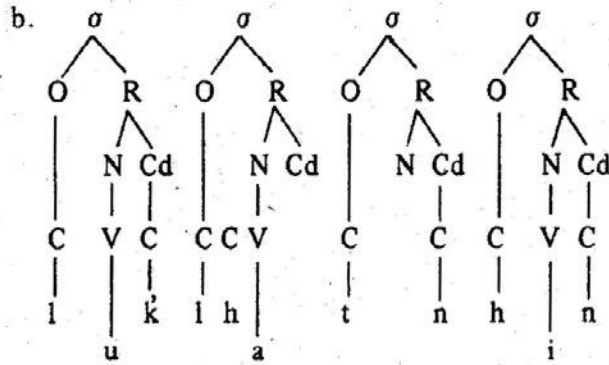

Note that in (46a,b) the *C* which finds itself above *h* but is not linked to it has not been syllabified, because the syllable structure conditions in (31) and (32) do not allow for skeletal slots that are not linked to a melodic tier to be syllabified (although the conditions *do* allow for empty syllabic nodes). Note also that (46a) contains three empty syllabic nodes and (46b) two. If we now link the *C* to the *h* below it the results are (after automatic resyllabification) as in (47):

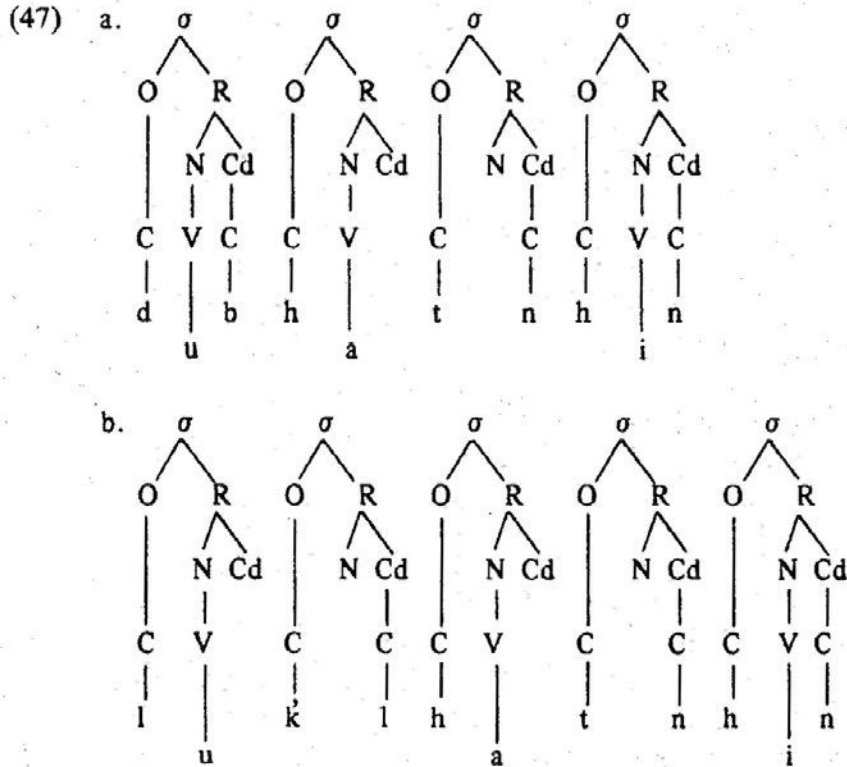

We see that in (47a) the number of empty syllabic nodes has decreased by 1, but that in (47b) it has increased by 2. Therefore, STAR in conjunction

with the condition on its application in (44b) will link *h* to *C* in (46a), producing the correct result *dubhatinhin*, but will not link *h* to *C* in (46b), because the number of empty nodes would then increase instead of decrease. The correct form *luklatinhin* is thus produced, instead of \**lukulhatinhin* (the form which would eventually come out of (47b) (after epenthesis and vowel harmony)). The alternations *-hne:l-/-ne:l-* (passive consequent gerundial; Newman, p. 134), *-lsa:-/-sa:-* (causative-repetitive; Newman, p. 94) as well as *-?hana-/-hana-*, (passive verbal noun; Newman, p. 149) occurring in the very closely related dialect of Wikchamni, are conditioned in exactly the same way.

I now come to the *-?(h)iy-* case, which as shown in section 1, cannot be handled by Archangeli's analysis. The two examples in (18) can be assumed to have the intermediate forms in (48), after application of morphological rule (28c), which the affix triggers,<sup>12</sup> and initial syllabification.

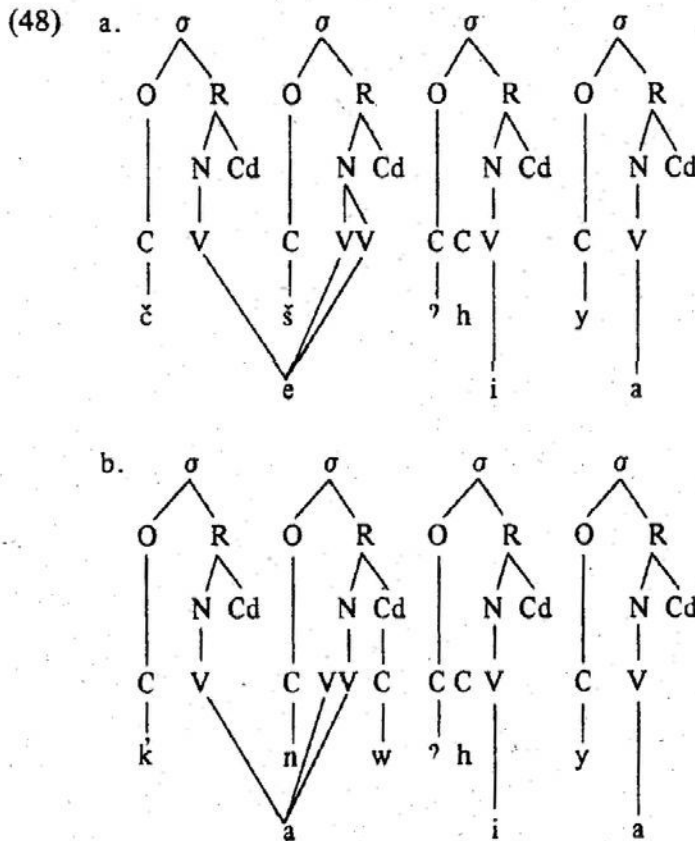

The number of empty syllabic nodes in (48a) is 4, in (48b) it is 3. Linking of *h* to *C* followed by automatic resyllabification will decrease the number of empty syllabic nodes in (48a), but will increase it in (48b), cf. (49a,b):

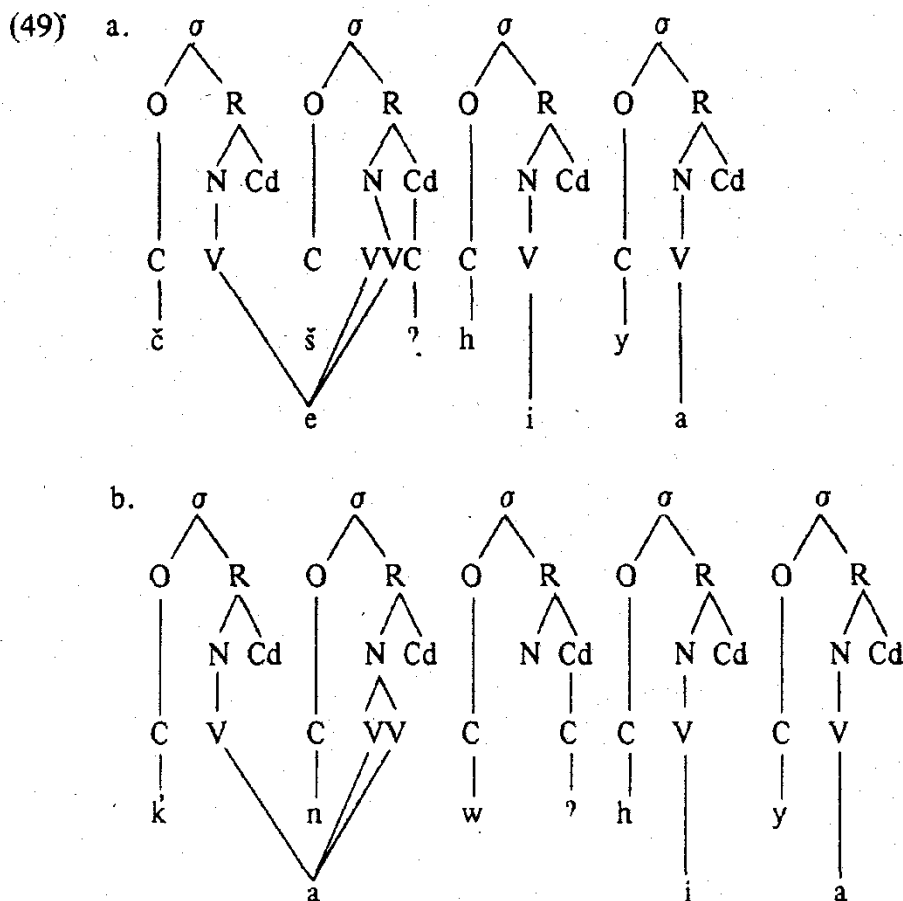

In (49a), the number of empty nodes has decreased by 1, in (49b) it has increased by 2 (in the empty nucleus eventually a  $\bar{Y}$  would be inserted, producing \**kanaawi<sup>h</sup>hiya*). Because it would increase the number of empty syllabic nodes, STAR does not apply in (43b), the final outcome thus being *kanaw<sup>h</sup>iya*, which is the right result. It does apply, however, in (43a), thus producing the form in (49a), phonetically *češe<sup>h</sup>hiya*.

We now come to the alternations of the *-k(a)* type, which as shown in section 1, Archangeli's system cannot account for either. Before the possible application of STAR, the forms in (24) and (25) have the representations as in (50a,b):<sup>13</sup>

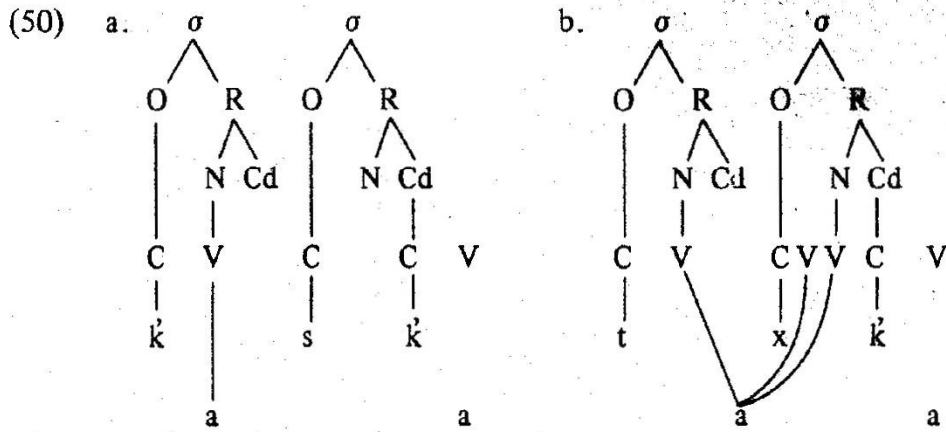

If the unassociated V's and a's are linked, the outcome after automatic resyllabification will be as in (51a,b):

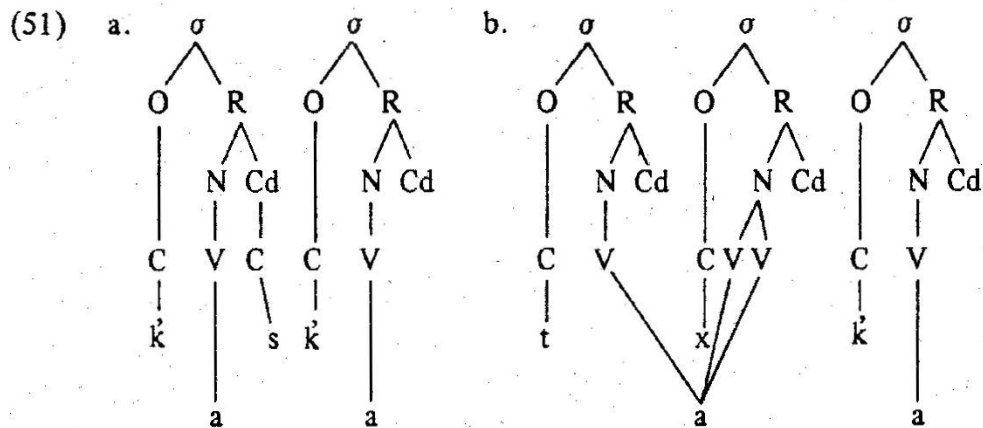

Note that in (50a) there are two empty syllabic nodes (in the empty nucleus a V would eventually be epenthesised), while in (51a) there is only one empty syllabic node. Therefore, STAR will indeed apply and produce the phonetic form *kaska*. In (50b), however, there is only one syllabic node, while in (51b) there are three. Hence in this case STAR does not apply and the phonetic outcome will be *taxak*.

It now becomes clear why I have assumed that spreading takes place only within the stem. Spreading throughout the form would link the empty V in the case of *taxak* with the stem vowel.

Now it can also be made clear why I have not chosen for a simple projection rule instead of the conditioned association rule STAR. Consider the form in (52), which would replace the intermediate form in (50a) if there would not be an unlinked V in the skeleton:

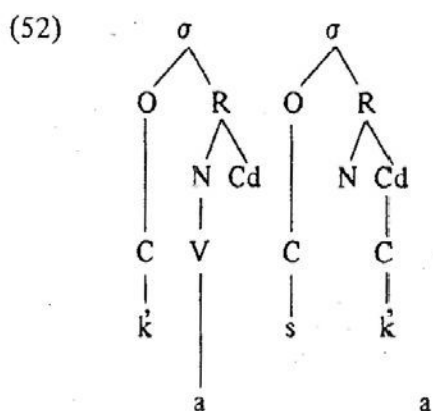

Because the consonantal segment  $k$  of the affix is on a different tier as the vocalic segment  $a$  of the affix, these two segments do not maintain an ordering relationship on the segmental levels. Therefore, under the assumption of a rule which projects a skeletal slot for a segment, applying under the same conditions as STAR, a V could also be projected to the left of the C linked with  $k$ , because automatic resyllabification would produce the same number of empty syllabic nodes, cf. (53):

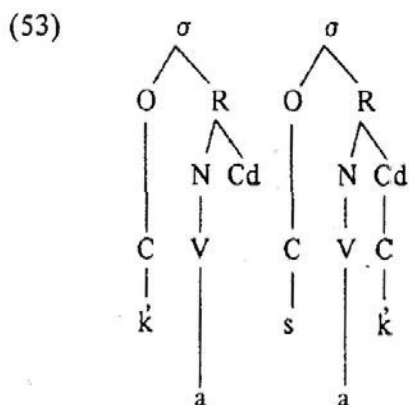

In (53), the number of empty syllabic nodes is 1, which is the same as the number of empty syllabic nodes in (51a). The principle of projection would thus incorrectly predict that  $*k'asak'$  should be a possible form along with  $k'aska$ . Therefore, I assume that there is an unlinked V in the skeleton which expresses the ordering relationship between  $k$  and  $a$ .<sup>14</sup>

Having shown how STAR can handle the  $-(h)atn-$ ,  $?(h)iy-$  and  $-k'(a)$  types of alternation, I will now treat yet another type of alternation, which my system can also account for. This concerns the dubitative morpheme  $-(a)l$  (Newman, p. 120). If adjoined to a stem with a final vowel, this morpheme behaves exceptionally in that it is not the stem-final vowel that is deleted (which is normally the case, since if two vowels are

conjoined in Yawelmani, the leftmost vowel is deleted, cf. Elision in (4) and my treatment of this phenomenon in section 3), but the vowel of the affix. This can be accounted for elegantly within the theory proposed here by assuming that this affix has the underlying form in (54), in which the first skeletal slot and *a* are not linked with each other.

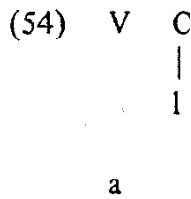

If the dubitative affix is concatenated with a vowel final stem the results of application and nonapplication of STAR are as in (55a) and (55b) respectively (after automatic resyllabification; the example *téhe[-]* < \**tíhe*, 'get skinny, get lean' has been taken from Newman, p. 120).

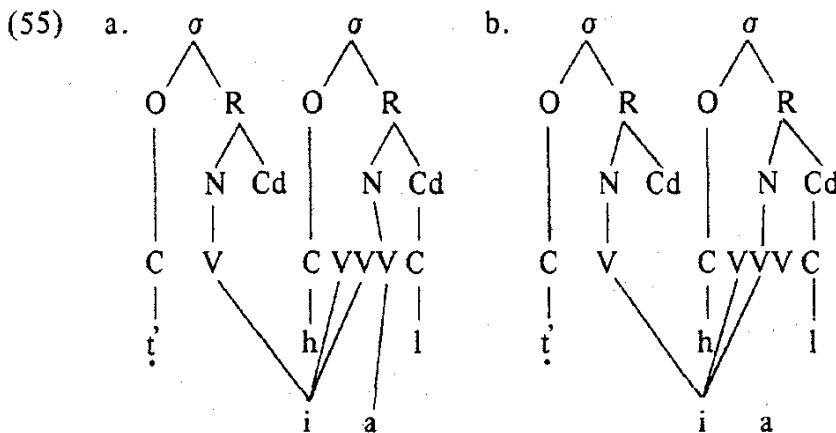

The structures in (55a,b) have the same number of empty syllabic nodes, viz. 1. Because of the requirement that STAR may apply only if the number of empty syllabic nodes of the output is less than that of the input, STAR may not apply and the correct form is the one in (55b), phonetically (after application of LVL (10)) *téhel*. If, on the other hand, *-(a)l* is concatenated with a consonant final verb stem, as in (56) (from Newman, p. 120), *a* is linked by STAR to the initially unlinked *V*, because application of STAR reduces the number of empty nuclei (otherwise the nucleus of the second syllable would be empty), cf. (57a,b):

(56) *šo·g-al* < \**šo·gu*, 'pull out an unfastened object'

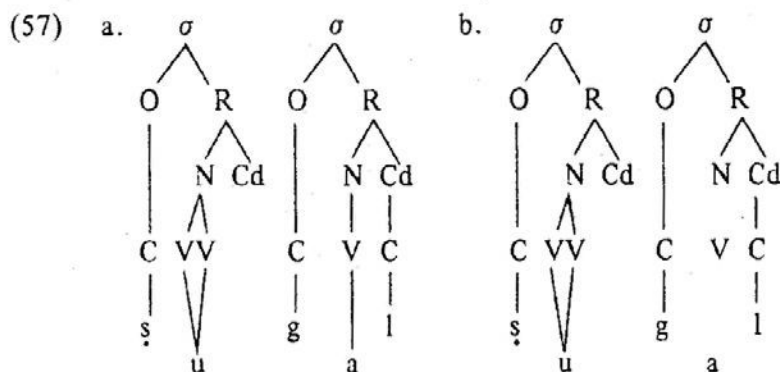

In (57b), the nucleus is not linked with *V*, because according to the syllable structure conditions in (32) the nucleus can be linked to *V* only if *V* is linked with an element on the vocalic melodic tier.

##### 5. CONCLUSION.

In this paper, I have shown that the syllable plays a decisive role in the conditioning of phonological alternations in Yawelmani. It was shown that the idea of local globality as used in Noske (1982) for French (i.e., the application of certain phonological rules is determined by the syllabic shape of the immediate output of these rules) can be regarded as the key to solving the notorious conspiracy in Yawelmani, which has been disregarded by phonologists over the past thirteen years, probably because of the generally prevailing distrust of functional explanations.

Extrapolating from this analysis of syllable changing processes in Yawelmani, I assume that in many languages elements on the consonantal and vocalic melodic tiers are underlyingly linked, and that if any association takes place in these languages, it takes place by rule. This can be seen as an extension of Pulleyblank's (1983) idea that spreading is not automatic.

The ideas advanced in this article are further strengthened by my analysis of the nominal system of Yawelmani, which will appear as a separate paper, due to limitations of space.

##### NOTES

1. Kisseberth actually formulates rule (1) in a slightly different way:

$$\emptyset \rightarrow V / C \_ C \begin{cases} \neq \\ C \end{cases}$$

pointing out that  $V=i$  in the regular case,  $a$  irregularly. The alternations involving  $a$



occur in the nominal system and in the dubitative morpheme *-(ə)l*. Cf. my treatment of this morpheme in section 4.

2. The exact formulation of the Shortening rule has been taken from Kuroda. Kisseberth's formulation is slightly different. The Elision rule in (4) is mentioned by Kuroda only.

3. Newman refers to these forms of the basic verb as *IA1*, *IA2* and *IB* for the biconsonantal verb roots and as *IIA1*, *IIA2* and *IIB* for the triconsonantal verb roots. The consonant-vowel configurations given here do not correspond to Newman's reconstructed base types, but to the actually occurring 'reduced stem', except for the omission of a few apparently epenthetic vowels (see Newman, p. 38-43).

4. Archangeli lists *-hin* as *-hn*, in which an *i* is inserted in the course of the derivation. Since there is no alternation, this morpheme always showing up with an *i*, it cannot be decided whether the vowel is epenthetic or underlying. In order to keep the data as transparent as possible, I present the vowel here as underlying.

5. This formulation is the one given by Archangeli (1983b:14). I have changed the feature [labial] to the less controversial [round]. Archangeli (1983a:359) uses a segmental formulation for the ease of exposition, but points out that the rule should be autosegmental in nature.

6. Archangeli also mentions (1983a:365) that the rules of Elision, Epenthesis and Shortening 'operate to permit proper syllabification of strings which are not transparently syllabified'. She does not, however, formalise the apparent relationship of these rules with syllabification. Like Kuroda and Kisseberth, she assumes a rule which she terms "Vowel Elision II" (VE II) which deletes a short vowel in what Kuroda (1967:17) terms a "two sided open syllable", i.e., the environment CV CV. I think this awkward rule does not exist, however. In the specimen of Yawelmani text provided by Newman (p. 240-2), out of 32 different words containing three or more syllables, five have a short vowel in such a position (viz. the forms numbered 27, 50, 51, 86, 101). In other parts of his book also Newman gives forms containing short vowels in 'two sided open syllables'. Kuroda uses this rule mainly to delete vowels that are inserted by overapplication of the insertion rule (1), a fact also pointed out by Kisseberth (1969). In my analysis this overinsertion does not occur. The only remaining problem, then, seems the mediopassive *-in-*. When combined with what Newman terms a "verbal theme" (an irregular verb not adopting different template forms), the affix resists truncation, even if followed by a vowel, e.g. *ho·y-in-* 'get sent', *?il-in-* 'get fanned' (Newman, p. 70), thus confirming the non-existence of VE II. But when combined with a regular verb *i* sometimes disappears. These forms, however, are explained by Newman in terms of analogical formation, "the fake base" (pp. 75-6). The "fake base" consists of a biconsonantal root and the mediopassive *-in-* (selecting a CVC(C) template). The base and the mediopassive morpheme together can analogically function as a new (triconsonantal) base, which is capable of adopting different template forms. Examples given by Newman involve the roots *xaya-* 'place, put', and *hūx-* (listed by Newman as *he·x-*) 'apply grease':

	'get fat'	'get placed'
	get greasy'	get into position'
Weak stem (=preconsonantal CVC(C) template)	xayi·n-	hixin-
Zero stem (=prevocalic CVC(C) template)	xayn-	hixn-
Strong stem (=CVCVV(C)), prevocalic	xaya·n-	hixe·n-
'    '                                  preconsonantal	xaya ·jn-	hixe ·jn-
Strong-zero stem (=CVC(C))	xa ·jyn-	he ·jxn-

The *i* is analogically treated as an epenthetic vowel, and is thus absent in places where epenthesis would not take place. Cf. also note 8.

7. The star in the forms cited from Newman indicates reconstructed forms, not ungrammatical ones. The consonant-vowel configurations in these forms are not always identical to one of the configurations given in (7). Cf. also note 3. All forms cited from Newman are from Yawelmani, except where indicated.

8. Archangeli (1983a:364, fn. 14) referring to an unpublished paper that I have been unable to consult (i.e., Archangeli (1983c)) that she proposes a rule that deletes a short vowel following any open syllable thus covering both the  $-k(a)$  type cases and the VE II cases. As in the case of VE II, this rule must be wrong. Apart from the counterexamples already mentioned in footnote 6, which also apply to this proposal, the specimen of text provided by Newman contains four more counterexamples to this proposal, i.e., the forms numbered 38 ( $\gamma\sigma k\sigma \cdot \acute{c}i$ ), involving the objective morpheme  $-i$ , 74/103 ( $ta \cdot ni$ ) and 98 ( $ta \cdot ne \cdot ni$ ) both involving the indirect objective  $-ni$ . Many more counterexamples can be found in other parts of the book, e.g. the direct objective forms  $\acute{t}\sigma k\acute{-}$  'the act of killing',  $\acute{c}e \cdot d \cdot a$  'greens', both forms involving the morpheme  $-a$  (p. 107-8) and  $nuso \cdot s \cdot u$  'paternal aunt', and the subjective form  $?ina \cdot sa$  'grandfather', (p. 212), involving the subjective  $-a$ .

9. This assumption is corroborated by the fact that in Yawelmani and in Yokuts in general there are verb roots of which the first two consonants are identical, but not the third one. Examples are

- \*wo·wul 'stand up' (Newman, p. 39) (for the star see note 7)
- \*lolow 'leave behind' (Chawchilla; Newman, p. 85)
- \*nɔnɔp 'make nine' (Chukchansi & Gashowu; Newman, p. 142; Wikchamni; Gamble, p. 42)

McCarthy (1979:146) points out that such a sequence is disallowed by autosegmental account of Arabic, because it violates the association conventions and Obligatory Contour Principle. If the consonants are lexically associated, however, the problem disappears.

10. I assume here a CV skeleton, although this contains redundant information, as pointed out by van der Hulst & Smith (1982:29), as well as Levin (1983). In fact the C's and V's can be replaced by unlabelled slots (say, X's) that indicate temporal relationships only. For the ease of exposition, I have kept C's and V's.

11. In Seri, there is a similar situation. Cf. the following Convention of Marlett & Stemberger's proposal for resyllabification (1983:619):

- Convention 3: "If a nonsyllabic position cannot be added to the following or the preceding coda, create a V to immediately precede it on the CV tier".

Marlett & Stemberger thus apparently assume a left-to-right application of syllabification, but their proposal entails a partial bidirectionality. This is also true for their second convention, which says that onsets should be maximised. With the assumption of a right-to-left syllabification here, there is no bidirectionality.

The idea of a right-to-left directional syllabification was first proposed by ter Mors (1982) for Klamath.

12. This is so because Newman mentions (p. 163) that this affix takes the "preconsonantal strong stem of all primary bases" which amounts to a  $CVCVV(C)$  template. Also the above mentioned morphemes  $-(h)ne:l-$ ,  $-(l)sa:-$ ,  $-(?)hana-$  take this template.

13.  $-k(a)$ ,  $-m(i)$  and  $-x(a)$  do not carry a diacritic triggering one the rules in (28), because they occur with the "preconsonantal reduced stem" (see note 3). Hence the "default template" is inserted.

14. If it were assumed that the vocalic elements and the consonantal elements of the affix were situated on one tier, the principle of projection would work, because the ordering relationship would then be expressed on that tier. Although it is the case that the affixes in Yawelmani behave differently from the verb stems, I have found no independent motivation for such an assumption.

## REFERENCES.

- Archangeli, D. (1983a), 'The Root CV-template as a Property of the affix: Evidence from Yawelmani', *Natural Language and Linguistic Theory*, 1, 347-384.
- Archangeli, D. (1983b), 'Yawelmani Verb Morphology and 3-dimensional Phonology', *NELS XIII*, 11-28.
- Archangeli, D. (1983c), *Underlying Representations and Syllable Structure in Yawelmani*, unpub. MIT.
- Csik, S. & E. Papa (1979), *Theoretical Issues Generative Phonology*, an annotated bibliography, Bloomington, Indiana: IULC.
- Davis, S. (1982), On the Internal Organization of Syllable Constituents, *Coyote Papers*, 3-22, Tucson, AZ: University of Arizona.
- Gamble, G. (1978), *Wikchamni Grammar*, University of California Publications in Linguistics, Berkeley.
- van der Hulst, H. & N.S.H. Smith, 'An overview of Autosegmental and Metrical Phonology', in van der Hulst H. & N.S.H. Smith (eds.), *The Structure in of Phonological Representations*, vol. I, 1-45, Dordrecht: Foris.
- Kahn, P. (1976), *Syllable Based Generalizations in English Phonology*, Ph.D. diss., MIT. published by IULC.
- Kiparsky, P. (1982), 'Lexical Phonology and Morphology', in I.-S. Yange (ed.), *Linguistics in the Morning Calm*, Seoul: Hanshin.
- Kiparsky, P. (1983), *Some consequences of Lexical Phonology*, unpub. ms. MIT.
- Kisseberth, C.W. (1970), 'On the functional Unity of Phonological Rules', *Linguistic Inquiry*, 1, 291-306.
- Kisseberth, C.W. (1969), *Theoretical Implications of Yawelmani Phonology*, Ph.D. diss. University of Illinois, Urbana.
- Kuroda, S.-Y. (1967), *Yawelmani Phonology*, Cambridge, MA: MIT Press.
- Levin, J. (1982), *Reduplication and Prosodic Structure*, unpub. ms. MIT.
- McCarthy, J. (1979), *Formal Problems in Semantic Phonology and Morphology*, Ph.D. Diss. MIT (pages cited from 1982 IULC edition).
- Marlett, S.A. & J.P. Stemberger, (1983) 'Empty Consonants in Seri', *Linguistic Inquiry*, 14/4, 617-639.
- Mohanan, K.P. (1982), *Lexical Phonology*, Ph.D. diss., MIT.
- Mors, C.H. ter (1982), *Empty V-nodes in Klamath*, M.A. thesis, Rijksuniversiteit Groningen.
- Newman S. (1944), *Yokuts language of California*, New York: Viking Fund Publications in Anthropology.
- Noske, R.G. (1982), 'Syllabification and Syllable Changing Rules in French', in van der Hulst, H. & N.S.H. Smith (eds.), *The Structure of Phonological Representations*, vol. II, 257-310, Dordrecht: Foris.
- Pulleyblank, D. (1983), *Tone in Lexical Phonology*, Ph.D. diss. MIT.