

## A PARAMETER OF SYLLABIFICATION\*

ROLAND NOSKE

*University of Amsterdam*

### *0. Introduction*

In the literature concerning the syllable (e.g., Kahn 1976), essentially one principle of assignment of syllable structure has been advanced: an algorithm which links elements to syllabic nodes in the following order:

- a. every vowel;
- b. a maximal number of consonants preceding every vowel; these consonants must form a permissible word-initial cluster;
- c. a maximal number of consonants following the vowel; these consonants must form a permissible word-final cluster.

Although there exists, according to this principle, a well-defined order of application within the syllable, nothing is said about the way the algorithm applies to a larger order of segments (e.g. a prosodic unit). Apparently, all the vowels are linked first, then the consonants which are going to form the onsets, and finally the codas. Thus, within a prosodic group which constitutes a domain for syllabification, all syllables are assigned simultaneously. This is why we wish to call this type of syllabification *non-directional*.

However, Kaye and Lowenstamm (1981:306-11) propose another principle: according to them, syllabification is *directional* and can take place from left to right in some languages, and from right to left in others. The principle of

---

\* We wish to thank Norval Smith for much valuable discussion, as well as for a number of corrections to our English. This work was supported by the *Stichting Taalwetenschap*, which is funded by the Netherlands Organisation for the Advancement of Pure Scientific Research (ZWO).

syllabification which they advance is given (1) and (2) (1981:307-9):

(1) The Rightward Strategy

Scanning a word from left to right, make the first syllable as unmarked as possible. If the resulting syllable on the right conforms to the formal and substantive constraints of the language, then there is a syllable boundary at that point. If the resulting right syllable violates a constraint, move the syllable boundary over one segment to the right and try again. Repeat until the resulting right syllable is licit. After the first syllable boundary has been found, repeat the process for each successive syllable until the end of the string is reached.

(2) The Leftward Strategy

Scanning a word from right to left, make the last syllable as unmarked as possible. If the resulting syllable on the left conforms to the formal and substantive constraints of the language, then there is a syllable boundary at that point. If the resulting left syllable violates a constraint, move the syllable boundary over one segment to the left and try again. Repeat until the resulting left syllable is licit. After the first syllable boundary has been found, repeat the process for each successive syllable until the beginning of the string is reached.

We refer the reader to Kaye and Lowenstamm (1981) for an explanation of their concept of markedness. It will suffice here to mention the concrete examples mentioned by the authors as motivation for their theory. As a language using the Rightward Strategy they mention English of which they give the following examples:

- (3) a. command    kə-mænd  
       b. canteen    kæn-tiyn  
       c. astute     a-stuwt

Although in English the segments or clusters of segments *m*, *nt*, *st* are permissible word-finally, the syllable boundaries are not located after these segments or clusters of segments but at the first possible place (going from left to right) (provided it is possible to syllabify the whole word, which is the reason that in (3b), the syllable boundary is placed after the *n*). In (3b, ~~a~~) the syllable-initial position of the dental plosives can be proved by the fact that they are aspirated.

As a language which uses the Leftward Strategy Kay and Lowenstamm mention Polish. Speakers of Polish generally agree that the syllabification of words like *wyspa* 'island', *ospa* 'smallpox', *tykwa* 'pumpkin', *stacja* 'station' is as in (4):

- (4) *wys-pa os-pa tyk-wa stac-ja*

This syllabification can be explained if the Leftward Strategy (2) is adopted. The Rightward Strategy (1) would give rise to syllabifications like *\*wy-spa*, *\*ty-kwa*, etc.

Independently of the proposals by Kaye and Lowenstamm, Ter Mors (1982) proposes a directional syllabification for Klamath, a Penutian language of Oregon. What is interesting here is that the direction of syllabification can be demonstrated in terms of epenthesis site.

In Klamath, an epenthesis process applies in order to resolve unsyllabifiable consonant clusters. Consider the underlying form in (5):

(5) /snogwk/

In this form, the sequence *gwk* is not a permissible word-final cluster. The syllable template of Klamath is given in (6):

(6) syllable template for Klamath

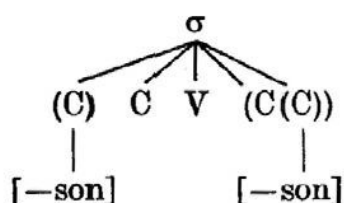

In order to make the sequence syllabifiable, there are two conceivable epenthesis sites: between *g* and *w*, and between *w* and *k*. In fact the process of epenthesis inserts the schwa between *g* and *w*, creating the form *snogəwk*. After having undergone an independently motivated vocalisation process, which changes *əw* to *o*: the form surfaces as (7):

(7) [snogo:k]

The form in (8), which would result if epenthesis were to take place between *w* and *k*, is ungrammatical.

(8) \*[snogwək]

As in many analyses concerning epenthesis, Ter Mors conceives of this process as the creation of a V on the level of the skeleton. This empty V is then filled up with the neutral vowel by a rule (or, according to the proposals of Archangeli (1984), by a *complement* rule):

(9) 
$$\begin{array}{c}
 V \\
 | \\
 \emptyset \rightarrow \text{ə} / \_
 \end{array}$$

The V on the skeletal level is assumed to have been inserted by the process of syllabification proper. It is thus that the relationship between epenthesis

and syllabic structure is established (recall that epenthesis functions in order to resolve otherwise unsyllabifiable sequences). The following syllabification mechanism is proposed by Ter Mors (1985:316):

- (10) *Rule of ASSOCIATION*: Map in a Rh [=right – to – left, RN fashion the syllable template onto the segmental trier; maximize clusters.

Because of the directionality, the following structure is created for /snogwk/:

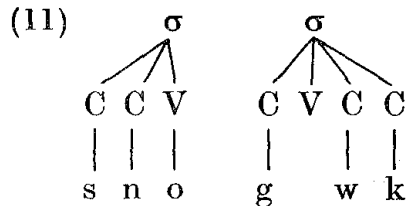

First,  $\begin{array}{c} C \\ | \\ k \end{array}$  and  $\begin{array}{c} C \\ | \\ w \end{array}$  are syllabified. Then the syllabification mechanism expects

a V. Because of the fact that the element which it then encounters is not a V, a V is inserted:

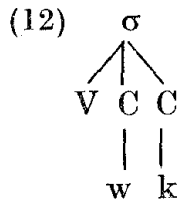

If one were to apply the well-known Maximal Onset Principle (incorporated in the proposal by Kahn), one would derive erroneously:<sup>1</sup>

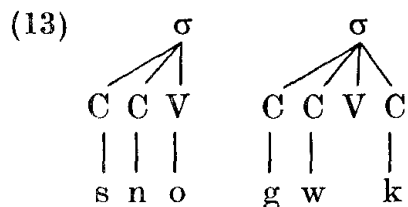

which, after application of (9) would produce the ungrammatical form in (8). We would get the same result if we were to adopt a left-to-right syllabification. Having outlined the essence of the proposal by Ter Mors, we will now show that the principle of directional syllabification accounts for certain processes in Yawelmani. We will see that the principle of directional syllabification re-

<sup>1</sup> In fact, this is not completely true. Strictly speaking, the maximal onset principle would fail to syllabify the second syllable altogether: in order to make an onset maximal it should be able to refer to the nucleus. Since there is no V to perform this function, the process of syllabification would be blocked.

ceives additional motivation because it explains certain syllabic processes other than epenthesis. Then, applying the principle to a third language, Tigrinya, we will see that the direction of syllabification is parametrised.

1. The syllabic processes in Yawelmani

Yawelmani, also a Penutian language (but not particularly closely related to Klamath), spoken in South Central California, has attracted a lot of attention from linguists. We mention here only the theses of Kuroda (1967), Kisseberth (1969) and Archangeli (1984). The main source is Newman (1944). Several processes affecting syllable structure take place in this language. The analysis we present here can be found in a more extended form in Noske (1985).

Yawelmani has three types of syllable: CV, CVC and CV: (CV<sub>1</sub>V<sub>1</sub>). Like Klamath, Yawelmani has an epenthesis process which serves to “repair” the syllabic structure. This is why we propose that in a certain phase of the derivation the nucleus<sup>2</sup> can be empty, into which vowels will be epenthised at a later stage. These are the well-formedness conditions for the onset and the rhyme in Yawelmani:

(14) possible Yawelmani onset

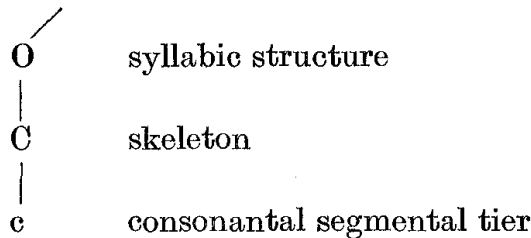

(15) possible Yawelmani rhymes

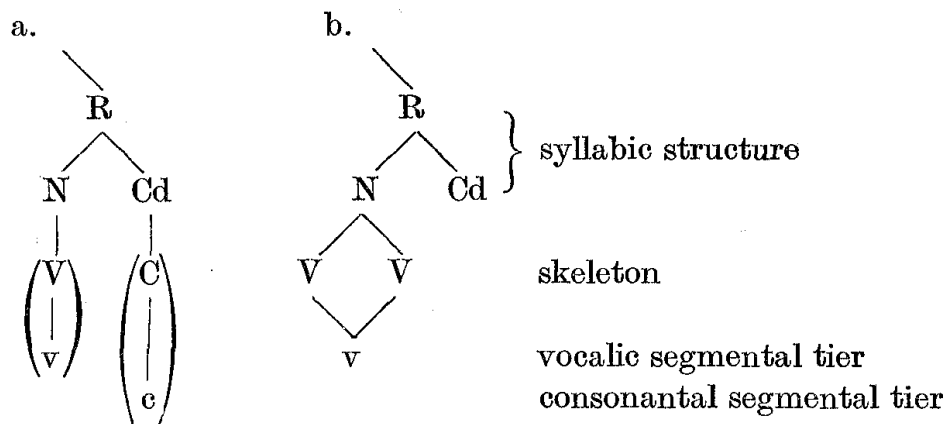

<sup>2</sup> We assume here the well-known *onset-rhyme* bipartition, with the rhyme being subdivided into *nucleus-coda*, for reasons that are outside the scope of this article, but which are given in Noske (1985).

In (15b) the coda is present, but obligatorily empty. The reasons for this do not concern us here, but are given in Noske (1985).

We propose the following syllabification principles for Yawelmani (cf. Noske 1985:347):

16) Syllabification principles for Yawelmani

syllable structures are mapped onto the skeleton

a. from right to left

b. in such a way that the number of empty syllabic nodes is minimised.

There are three reasons for the directionality. The first two concern the rules of Shortening and Elision postulated for Yawelmani by Kuroda (1967) and Kisserbeth (1969):

(17) Shortening:  $V \rightarrow [-\text{long}] / \_ C \left\{ \begin{array}{l} \# \\ C \end{array} \right.$

(18) Elision:  $V \rightarrow \emptyset / \_ V$

The functioning of Shortening can be seen in (19):

(19) /taxaa+t/ [taxat]  
taxaa-, 'bring'; -t, passive aorist

The functioning of Elision can be seen in (20):

(20) /lagaa+in+hin/ [laginhin] lagaa- 'spend the night'; -in-, mediopassive, -hn, aorist

Applying the syllabic well-formedness conditions given in (10, 11) as well as the syllabification principles in (16), one obtains the syllabic structure in (21):

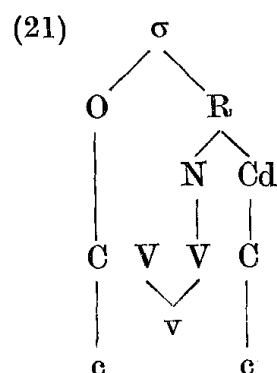

We now see that the process of shortening follows automatically from the retrograde character of syllabification: the mechanism will try to syllabify according to the templates in (15a, b). Because of the fact that it encounters a C, it will select (15a). Then, (continuing to go from right to left) it encounters the rightmost V, and links this to the nucleus node. Now a second V is en-

countered. Because of the fact that (15a) allows only one V to be linked to the syllabic structure, this V is then skipped and is therefore not realised, since we assume that in order to be pronounced an element on the CV-tier has to be linked to the syllabic structure.

We obtain a similar result to that in (21) with vowel elision in the case of a closed syllable. Cf. (22):

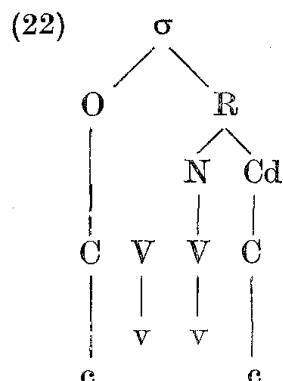

In (22), the retrograde syllabification links only the rightmost V to the syllabic structure, thus the V to its left is not realised, which is the correct result. For an open syllable, it is the requirement that the two contiguous V's be linked to a single element on the vocalic segmental tier that rules out the form in (23):

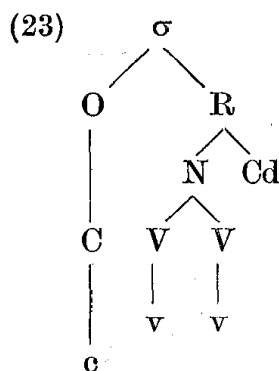

We thus see that two processes in Yawelmani which up till now have had to be explicitly stated in terms of rules, follow from the assumption of a directional syllabification mechanism. We now come to a third reason for the directionality. Consider the following two rules, proposed by Kuroda (1967) and Kisseberth (1969):

(24) Epenthesis:

$$\emptyset \rightarrow i / \_ C \begin{cases} \# \\ C \end{cases}$$

(25) Two Sided Open Syllable Deletion (Kuroda 1967:32):

$$\begin{array}{c} \text{V} \\ [-\text{long}] \end{array} \rightarrow \emptyset / \text{VC} \_ \text{CV}$$

The derivations in (26) illustrate the function of these two rules:

(26) *pa<sup>2</sup>t-*, 'fight'; *-hn*, aorist; *-t*, passive aorist

a.	<i>pa<sup>2</sup>t+hn</i>	b.	<i>pa<sup>2</sup>t+t</i>	Underlying Representation
	<i>pa<sup>2</sup>iti+hin</i>		<i>pa<sup>2</sup>it+it</i>	Epenthesis (24)
	<i>pa<sup>2</sup>it+hin</i>		<i>pa<sup>2</sup>it+t</i>	Two Sided Open Syllable Deletion (25)
	<i>pa<sup>2</sup>ithin</i>		<i>pa<sup>2</sup>tit</i>	Surface Representation

Instead of Epenthesis (24) we propose the following rule, which fills an empty node with the neutral vowel (which is *i* in Yawelmani):

(27) Epenthesis:

$$\emptyset \rightarrow \begin{array}{c} \text{N} \\ | \\ \text{V} \\ | \\ \text{i} \end{array} / \_$$

This rule differs from rule (9) only in that it refers to an empty syllabic node (nucleus), instead of an empty V. Let us now look at the structures that will be generated by our syllabification principles in (16) for the structure in (26):

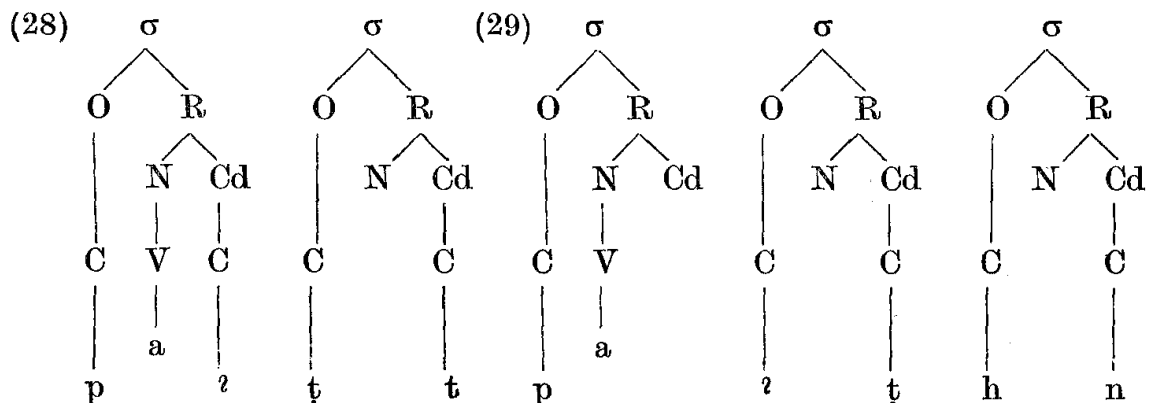

We see that the empty nodes are precisely in those places where we find an epenthetic vowel on the surface. We now see that we are able to posit a more general rule for the epenthesis process than in (24). Because our rule refers to syllable structure, it is endowed with explanatory power: it explains the fact that epenthesis takes place only in those cases where it is necessary to "repair" the syllabic structure. Note also that we do not need the Two Sided Open Sylla-



ble Deletion (25) here. It would indeed be strange that a vowel should be inserted first, only to be deleted later, as in the derivations in (26).<sup>3</sup>

If one assumes a syllabification from left to right, one would derive the structure in (30), which would give rise to the ungrammatical phonetic form in (31):

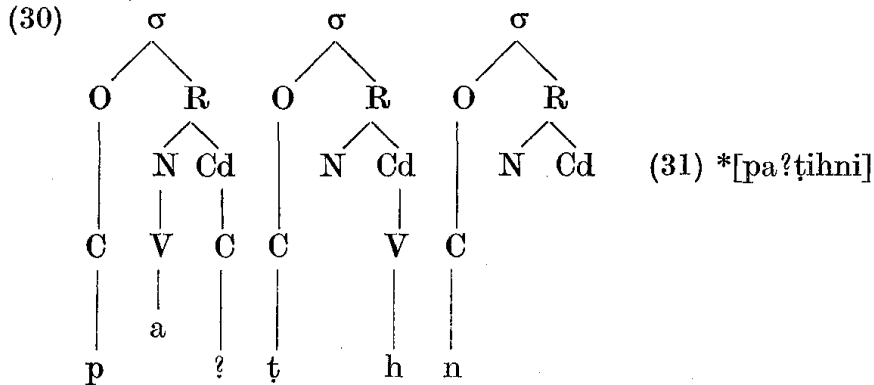

We thus see that the right-to-left directionality can account for three processes in Yawelmani. It is useful to mention a fourth reason here, of a more theoretical nature, which argues in favour of a retrograde syllabification. Consider what would happen if syllabification were to take place from left to right. If

C

the mechanism encountered a postvocalic |, it would not be able to decide to

c

which syllabic node this element were to be linked. For this, it would have to

C      V                      C

know whether the following element were a |, or a |. In the same case, the |

c              v                      c

would have to be assigned to the coda (of the former syllable), in the latter case to the onset (of the next syllable). This amounts to saying that we would have to be able to look ahead, which would entail a partial bidirectionality. This would make the mechanism unnecessarily powerful: a right-to-left application does not produce this kind of problem, at least not for CVC languages in which the onset is obligatorily filled. In order to see this consider what would happen if (going from right to left) the mechanism were to encounter a C after having linked the node of nucleus to a V. Because of the fact that the onset is obligatorily filled, it would always assign onset status to this C. There is thus

<sup>3</sup> Apart from cases like (26), the only motivation adduced for the rule of "Two Sided Open Syllable Deletion" (27) is constituted by the behaviour of the mediopassive morpheme *-in-*. However, as pointed out in Noske (1985 : 359), the deletion of *i* which can occur in this morpheme is the result of the analogical reanalysis of the verb stem followed by *-in-* as a monomorphemic verb stem (the so-called "fake base" (Newman 1944:75)). The *i* then alternates with zero, because it is reanalysed as an epenthetic vowel.

no need to “know” the nature of the element on the CV-tier (i.e., a C or a V) that is to the left of the C in question. By assuming right-to-left directionality, the mechanism can be kept as simple as possible.<sup>4</sup>

We can now raise the question whether right-to-left directionality is universal, or, to put the same question less strongly, whether this directionality is universal for CVC languages (i.e., a language in which the maximal syllable is CVC). This could be tested by investigating which stie is selected for the insertion of an epenthetic vowel in order to “repair” syllabic structure, like the one in (24). This boils down to asking the question in (32):

(32) Is the environment  $\_C \left\{ \begin{array}{l} \# \\ C \end{array} \right.$  universal in syllable repair in CVC languages?

We will see in section 2 that the answer to this question is negative. To see this, we will examine the process of Epenthesis in Tigrinya.

## 2. *The syllabic processes in Tigrinya*

Tigrinya, a South Semitic language of northern Ethiopia, possesses an epenthesis process which can operate word-internally as well as word-finally. Pam (1973) mentions two different rules, which he later combines. The first rule is given in (33) (1973 : 116):

(33)  $\emptyset \rightarrow i / CC\_ (C) \#$

The functioning of this rule can be seen in (34) (1973:114):

(34) a. /kalb+n/ [kɒbin] “dog”+suffixed conjunction  
 b. /kalb/ [kɒlbi:] “dog”

In (34b) the *i* has been lengthened by a lengthening rule given in (35) (1973 : 115):

(35)  $i \rightarrow i: / \_ \#$

---

<sup>4</sup> We are indebted to Professor Werner Winter for indicating to us that an earlier version of our text was unclear on this point. If a CVC language allows empty onsets, but does not allow syllabifications of the type CVC\$VC (where \$=syllable boundary), a syllabification excluded by its high degree of markedness in terms of Kaye & Lowenstamm’s proposals (whatever the direction of syllabification), we can make our prediction more general and posit that left-to-right syllabification is the marked setting for CVC languages in general. As the reader will have noted, the suggestions made by Kaye and Lowenstamm also imply a partial bidirectionality. However, we think that a language tends to choose the direction of syllabification which implies the fewest complications, other things being equal, and that therefore a CVC language would tend to select the right-to-left syllabification.

The second epenthesis rule is given in (36) (1973:111):

$$(36) \emptyset \rightarrow i / \# C \_ C$$

An example of the functioning of this rule can be seen in (37):

$$(37) /sbar/ [sibar] \text{ 'break'}$$

Pam combines these two rules as in (38) (1973:117):

$$(38) \emptyset \rightarrow i / [-syll] [-syll] \_ [-syll]$$

Pam thus has to resort to the expression  $[-syll]$ , i.e. he has to treat word boundaries on a par with consonants. He thus has to specify these elements negatively with regard to their syllabicity. This is not very satisfying for in fact word boundaries and consonants have very little in common. This is the reason why phonologists have stopped referring to word boundaries as  $[-syll]$ . One can now ask the question whether in Tigrinya, as in Yawelmani, the epenthesis process can be analysed as the result of the process of syllabification. For this, it is necessary to know what the maximal syllable in Tigrinya is, and whether epenthesis takes place only if the process of syllabification is confronted with an otherwise unsyllabifiable sequence.

The answers to both questions are straightforward: the syllable structure of Tigrinya is CV (V) (C), the maximal syllable being thus CVVC, and Epenthesis operates only in those structures where otherwise a more complex consonantal syllabic structure than CVVC would ensue.

We can now see that the rules in (33) and (36) can be dispensed with if we assume a *left-to-right* syllabification, in the same way as the right-to-left syllabification in Yawelmani we proposed above: if a C is encountered by the syllabification mechanism at a place where it only expects a V, a V is projected, and later filled by the neutral vowel (in the case of Tigrinya *an ʒ*). If we adopt such an analysis, we can express the process in a unitary way, without having to resort to references to  $[-syll]$ . The only difference from the Yawelmani case is that the directionality of syllabification is reversed, and that the quality of the epenthetic vowel is slightly different (*ʒ* instead of *i*). It can thus be stated that the parameter of the directionality of syllabification is set differently for Tigrinya and Yawelmani.

Not only does the epenthesis process provide motivation for the directionality of the syllabification process, but this is also the case with a process of vowel deletion, operating in an opposite fashion to Yawelmani. Thus is formulated by Pam (1973:76) as in (39).

(39) Vowel Elision (Pam 1973:76):

$$V \rightarrow \emptyset \begin{matrix} V \\ [+long] \_ \end{matrix}$$

The structural description of this rule is the mirror image of that of rule (18), formulated by Kisseberth for vowel elision in Yawelmani, except in its requirement that the vowel be long, which follows from the fact that Tigrinya allows two V's in a closed syllable (the two V's represent a long vowel or a diphthong). An example of the application of rule (39) is given in (40) (Pam 1973:77).

(40) Base	r i <sup>2</sup> s	
a + — prefixation	a +	
Infixation	a:	
Vowel Elision	Ø	
Output	a + ra: <sup>2</sup> s	'heads'

This form surfaces as [ara : <sup>2</sup>is]. (The place where the epenthesis takes place seems to contradict rule (33), as well as our reanalysis of it. However, Pam (1973:117-8) points out that the epenthesis site is exceptional and is restricted to the class of words to which the form in (50) belongs, thus there seems to be a morphological conditioning here).

We will now make a final point. As was mentioned in section 1, given a directionality in the syllabification mechanism, one would expect it to be right-to-left rather than left-to-right because of the fact that in the latter case the mechanism would have to look ahead. The right-to-left directionality would thus constitute the unmarked case. This seems indeed to be confirmed by the facts. There are many CVC languages where  $\_C \left\{ \begin{array}{l} \# \\ C \end{array} \right.$  is the environment for syllable repair. A situation such as the one in Tigrinya, however, where the environment for syllable repair could be formulated as  $\left. \begin{array}{l} \# \\ C \end{array} \right\} C \_$ , seems to be very rare, and must be assumed to be the marked case. This conjecture is confirmed if we look at the situation in languages closely related to Tigrinya, e.g., Tigre. In Tigre, the equivalent of (34b) is as in (4):

(41) [kAlib]

This form is also found in other related languages. Hence it must be concluded that in Tigre, syllabification takes place from right to left, the unmarked direction, and that Tigrinya is exceptional in its left-to-right syllabification.

### 3. Conclusion

We have shown that the principle of directional syllabification proposed by Ter Mors (1982) in order to explain the process of epenthesis in Klamath, as well as by Kay and Lowenstamm (1982) in order to account for the difference in the distribution of syllable boundaries between English and Polish,

receives additional motivation from the syllabic processes in Yawelmani such as epenthesis and vowel elision. It was shown that in Tigrinya too, syllabification must be assumed to take place directionally, but that in this language it applies from left to right, in contrast to Klamath and Yawelmani. The implicit conclusion in Kaye and Lowenstamm, i.e. that the *direction* of syllabification is a *parameter*, is thus shown to be correct. It is plausible that the *left-to-right* syllabification is the marked setting of the directionality parameter for CVC languages with a obligatorily filled onset.

## REFERENCES

- Archangeli, D. 1984. *Underspecification in Yawelmani phonology and morphology*. Unpublished Ph. D. dissertation, the M.I.T.
- Belletti, A. et al. (eds). 1981. *Theory of markedness in generative grammar*. Pisa: Scuola Normale Superiore di Pisa.
- Kahn, D. 1976. *Syllable-based generalizations in English phonology*. Unpublished Ph. D. dissertation, the M.I.T.
- Kaye, J. and Lowenstamm, J. 1981. "Syllable structure and markedness theory". In Belletti, A. et al. (eds). 1981. 287-315.
- Kisseberth, C. W. 1969. *Theoretical implications of Yawelmani phonology*. Unpublished Ph. D. dissertation, University of Illinois, Urbana.
- Kuroda, S.-Y. 1967. *Yawelmani phonology*. Cambridge, Mass.: The M.I.T. Press.
- Newman, S. 1944. *Yokuts language of California*. New York: Viking Fund Publications in Anthropology.
- Noske, R. 1985. "Syllabification and syllable changing processes in Yawelmani". In Van der Hulst, H. and Smith, N. S. H. (eds). 1985. 335-61.
- Pam, M. D. 1973. *Tigrinya phonology*. Unpublished Ph. D. dissertation, City University of New York.
- Ter Mors, C. 1985. *Empty-Vnodes and their role in Klamath vowel alternations*. In Van der Hulst H. and Smith N. S. H. (eds). 1985. 313 - 33.
- Van der Hulst, H. and Smith, N. S. H. (eds). 1985. *Advances in nonlinear phonology*. Dordrecht: Foris Publications.